



# Tongue-type nozzles with dovetail and captive cap nut



## Series 686. XXX.WW.09

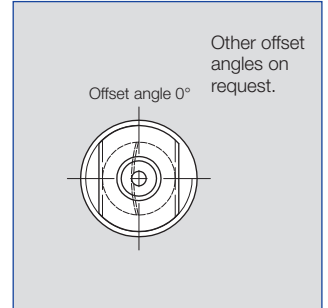
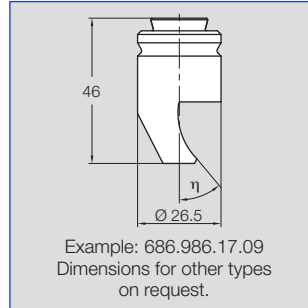

**Wide, sharply defined flat fan pattern.**  
**Non-clogging.**  
**Automatic jet alignment due to dovetail guide.**  
**Captive cap nut for easy maintenance.**

Applications:  
 Pickling, rinsing.



Spray angle 	η	Ordering no.		B Ø [mm]	ṽ [l/min]			Spray width B  at p=2 bar H = 250 mm
		Type	Mat. no. 17 <sup>1</sup> AISI 316Ti/ AISI 316L		p [bar]			
					1.0	2.0	5.0	
90°	40°	686.646	○	2.2	2.83	4.00	6.32	530
		686.686	○	2.4	3.54	5.00	7.91	530
		686.726	○	2.7	4.45	6.30	9.96	530
		686.766	○	3	5.66	8.00	12.65	530
		686.806	○	3.4	7.07	10.00	15.81	530
		686.846	○	3.8	8.84	12.50	19.76	530
		686.886	○	4.2	11.31	16.00	25.3	530
		686.926	○	4.7	14.14	20.00	31.62	530
		686.966	○	5.3	17.68	25.00	39.53	530
686.986	○	5.6	19.80	28.00	44.27	530		
140°	75°	686.648	○	2.2	2.83	4.00	6.32	1370
		686.688	○	2.4	3.54	5.00	7.91	1370
		686.728	○	2.7	4.45	6.30	9.96	1370
		686.768	○	3	5.66	8.00	12.65	1370
		686.808	○	3.4	7.07	10.00	15.81	1370
		686.828	○	3.6	7.92	11.20	17.71	1370
		686.848	○	3.8	8.84	12.50	19.76	1370
		686.888	○	4.2	11.31	16.00	25.30	1370
		686.908	○	4.5	12.73	18.00	28.46	1370
		686.928	○	4.7	14.14	20.00	31.62	1370
		686.948	○	4.9	15.84	22.40	35.42	1370
		686.968	○	5.3	17.68	25.00	39.53	1370
		686.988	○	5.6	19.80	28.00	44.27	1370

<sup>1</sup>We reserve the right to deliver AISI 316Ti or AISI 316L under the material no. 17.  
 B = Bore diameter  
 Other types and materials on request.

**Example**    **Type**    **+ Material no.**    **+ Code**    **= Ordering no.**  
**of ordering:**    **686.646**    **+ 17**                    **+ 09**                    **= 686.646.17.09**

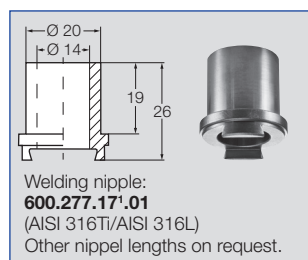
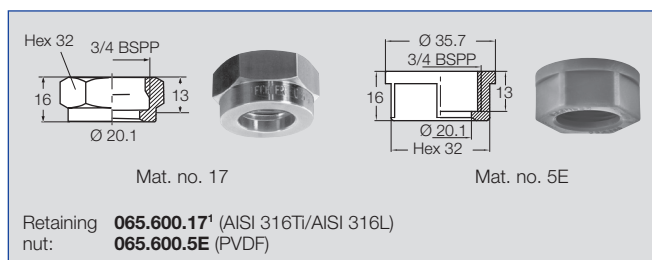

Welding nipples and cap nuts must be ordered separately. Please see folded page at the end of the catalogue for suitable accessories.

<sup>1</sup>We reserve the right to deliver AISI 316Ti or AISI 316L under the material no. 17.

**Conversion formula for the above series:**  $\dot{V}_2 = \dot{V}_1 * \sqrt{\frac{p_2}{p_1}}$

