

# Roll Cooling flat fan nozzle Series 6F

**Patented**

The correct alignment of the roll cooling nozzles on the spray header is essential for optimal roll cooling. Flat fans are the preferred spray pattern for roll cooling, therefore only a self-aligning nozzle design provides the operation safety required in a modern rolling mill.

All flat fan nozzles of the Lechler series 6F4 and 6F5 come with an automatic self-aligning feature which ensures

that every nozzle will always be installed under the correct spray offset angle towards the roll center line. The nozzle tip has two locating lugs for self-alignment and seals metallurgically with a circular surface against the welding nipple when the nut is tightened.

No torque is applied on the lugs themselves preventing mechanical damage due to over-tightening of the nut. The 6F nozzle series are

ideal for mounting when space is limited.

Unlike the dove tail assemblies the tip is put in in axial direction of the welding nipple.

Safe and one-handed nozzle tip mounting is guaranteed because thread engagement does not take place before the two location lugs have been correctly positioned on the opposite nipple side.

The 6F nozzle series is available with a wide variety of standard offset angles which simplifies spray header fabrication significantly. It also helps to prevent wrong fabrication of headers.

The spray has a parabolic liquid distribution which is ideal for a multi-nozzle header arrangement

- Parabolic liquid distribution
- Automatic nozzle alignment
- High operation safety
- Secure one-handed axial mounting
- Mechanical damage prevented
- Variety of standard offset angles
- Design and fabrication errors prevented

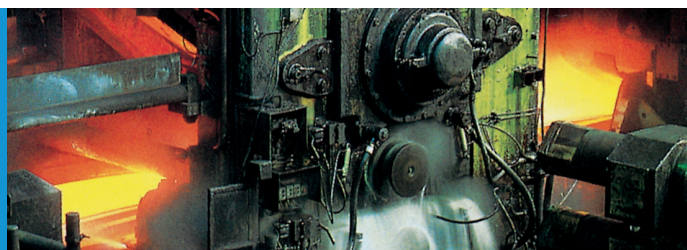
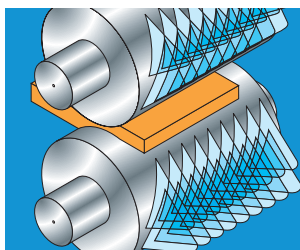
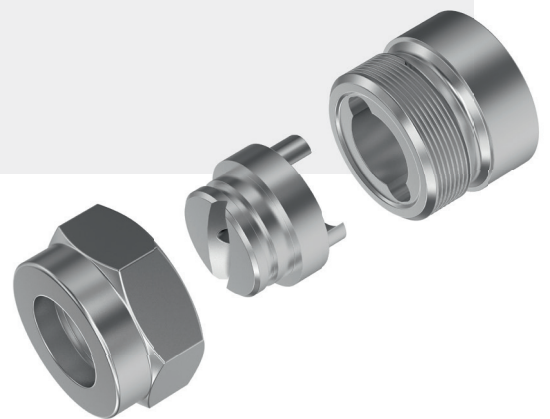
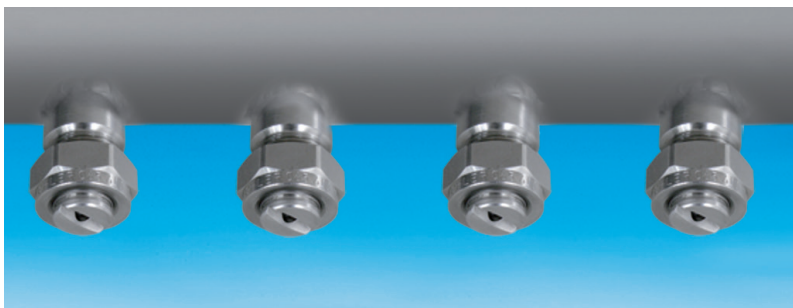
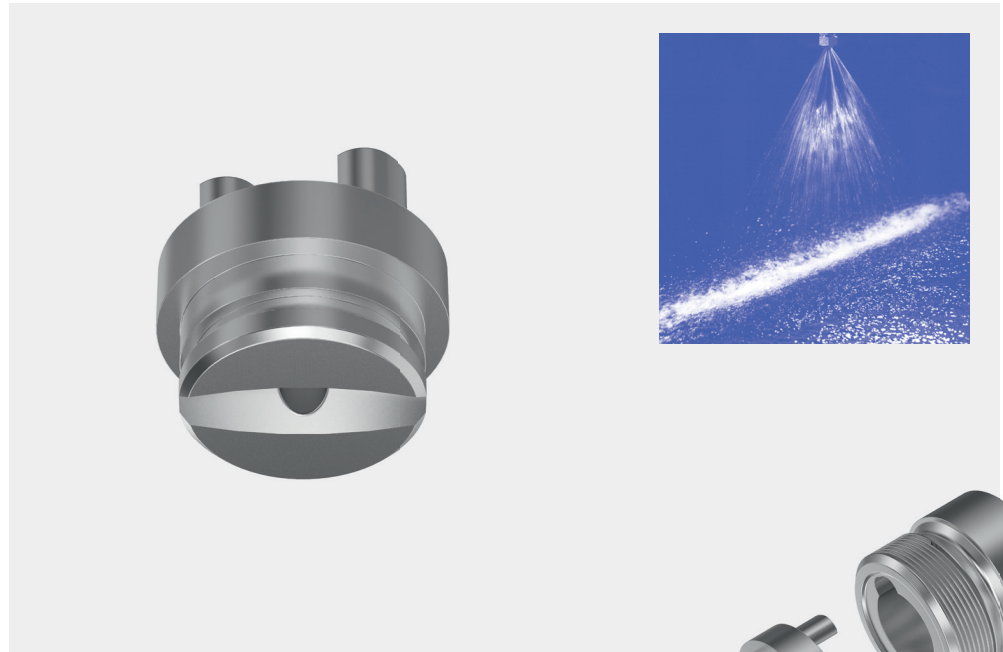

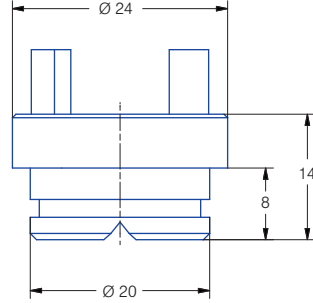

Nozzle series 6F4/6F5  
Weight: 38 g

Spray width [B] at p=3 bar	H	
	250 mm	500 mm
6F4.721-6F4.921	100	200
6F4.941-6F5.201	115	210
6F4.722-6F4.962	150	300
6F4.982-6F5.202	160	310
6F4.723-6F4.963	220	440
6F4.983-6F5.203	250	490
6F4.724-6F4.964	330	630
6F4.984-6F5.204	340	640

Ordering code for offset angle	
Offset angle $\gamma$	Ordering code
15°	<b>15</b>
20°	<b>20</b>
25°	<b>25</b>
30°	<b>30</b>
35°	<b>35</b>
40°	<b>40</b>
45°	<b>45</b>
50°	<b>50</b>
60°	<b>60</b>
70°	<b>70</b>

### Accessories

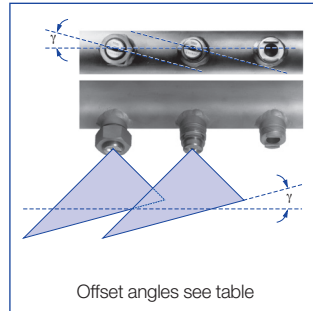
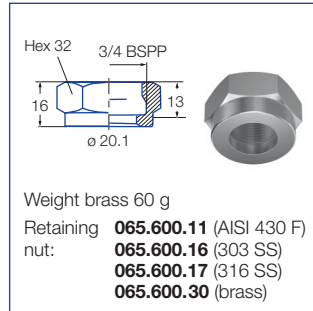
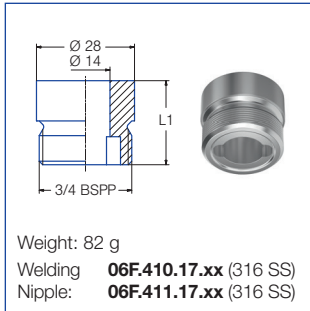

Technical data and ordering data for accessories see page 18.

Ordering no.						E Ø [mm]	$\dot{V}$ [l/min]								
Type				Mat. no.			$\gamma$	p [bar]							
20°	30°	45°	60°	17 316 SS	30 Brass			[US gal./min] at 40° psi							
6F4.721	6F4.722	6F4.723	6F4.724	○	○	code for offset angle see separate table below	2.1-2.5	3.15	4.45	6.30	1.95	7.72	9.96	11.79	14.09
6F4.761	6F4.762	6F4.763	6F4.764	○	○		2.3-2.8	4.00	5.66	8.00	2.48	9.80	12.65	14.97	17.89
6F4.801	6F4.802	6F4.803	6F4.804	○	○		2.6-3.2	5.00	7.07	10.00	3.10	12.25	15.81	18.71	22.36
6F4.841	6F4.842	6F4.843	6F4.844	○	○		3.0-3.6	6.25	8.84	12.50	3.88	15.31	19.67	23.39	27.95
6F4.881	6F4.882	6F4.883	6F4.884	○	○		3.4-4.0	8.00	11.31	16.00	4.96	19.60	25.30	29.93	35.78
6F4.921	6F4.922	6F4.923	6F4.924	○	○		4.1-4.4	10.00	14.14	20.00	6.20	24.49	31.62	37.42	44.72
6F4.941	6F4.942	6F4.943	6F4.944	○	○		4.6-5.0	11.20	15.84	22.40	6.94	27.44	35.42	41.91	50.09
6F4.961	6F4.962	6F4.963	6F4.964	○	○		4.2-5.3	12.50	17.68	25.00	7.75	30.62	39.53	46.77	55.90
6F4.981	6F4.982	6F4.983	6F4.984	○	○		4.2-5.1	14.00	19.80	28.00	8.68	34.29	44.27	52.38	62.61
6F5.001	6F5.002	6F5.003	6F5.004	○	○		4.8-5.6	15.75	22.27	31.50	9.76	38.57	49.80	58.92	70.43
6F5.011	6F5.012	6F5.013	6F5.014	○	○		4.9-5.8	16.75	23.69	33.50	10.40	41.03	52.97	62.67	74.91
6F5.041	6F5.042	6F5.043	6F5.044	○	○		5.5-6.6	20.00	28.28	40.00	12.41	48.99	63.25	74.83	89.44
6F5.061	6F5.062	6F5.063	6F5.064	○	○		5.8-6.7	22.50	31.84	45.00	13.96	55.15	71.20	84.24	100.69
6F5.081	6F5.082	6F5.083	6F5.084	○	○		6.6-7.4	25.00	35.36	50.00	15.50	61.24	79.06	93.54	111.80
6F5.121	6F5.122	6F5.123	6F5.124	○	○		7.4-8.3	31.50	44.55	63.00	19.56	77.16	99.61	117.86	140.87
6F5.161	6F5.162	6F5.163	6F5.164	○	○		8.3-8.4	40.00	56.57	80.00	24.80	97.99	126.50	149.68	178.90
6F5.181	6F5.182	6F5.183	6F5.184	○	○		8.9-10.3	45.00	63.64	90.00	27.90	110.23	142.30	168.37	201.24
6F5.201	6F5.202	6F5.203	6F5.204	○	○		9.6-10.5	50.00	70.71	100.00	31.04	127.47	158.11	187.08	223.61

E = narrowest free cross section · Subject to technical modifications.

Example Type + Material no. + Offset angle = Ordering no.  
of ordering: **6F4.721 + 17 + 15 = 6F4.721.17.15**

Conversion formula for the above series:  $\dot{V}_2 = \dot{V}_1 * \sqrt{\frac{p_2}{p_1}}$

