

# OPTIMISATION OF TECHNOLOGIES FOR HYDRO-MECHANICAL DESCALING OF STEEL

Jürgen W. Frick  
Lechler GmbH  
D-72555 Metzingen / Germany  
E-mail : [frju@lechler.de](mailto:frju@lechler.de)

## Abstract

As well as the customers in the automotive industry, manufacturers of construction and agricultural machinery using hot rolled steel for outer body parts demand defect free surfaces. The production of oil and gas pipe lines has also set very stringent surface quality standards to the plate mills rolling API steel grades. Existing rolling mills entering into these lucrative markets for high quality steel often struggle to fulfill those quality requirements because of the limitations of the descaling systems installed in terms of pressure and flow rate. In addition to the potential for optimizations of existing systems, the potential for optimization of the nozzle design itself has now been fully utilized in order to maximize the impact at a given water flow and pressure. New design methods and production technologies have been applied.

This paper describes the:

1. Nozzle spray characteristics
2. Optimisation of impact measurement technology
3. Design features of conventional descaling nozzles
4. Main new design features of the new descaling nozzle Scalemaster Superior
5. CFD – Computational Fluid Dynamics
6. Reduction of nozzle internal pressure loss
7. Reduction of nozzle internal turbulences
8. Explanation of impact increase of Scalemaster Superior
9. User benefits of the new descaling nozzle Scalemaster Superior
10. Conclusion

**Figure 1** shows a typical nozzle arrangement and a list of terms and symbols which are used hereafter.

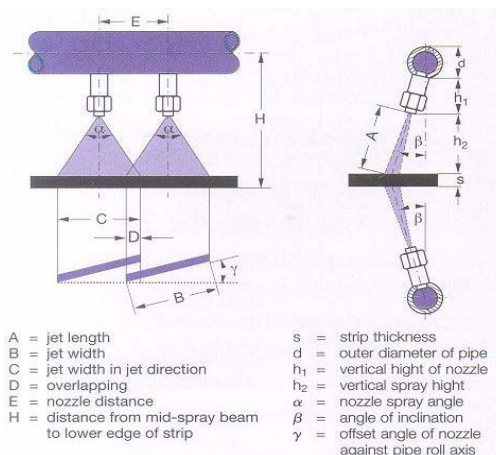

**Fig. 1: Terms and symbols in descaling**

# 1. Nozzle Spray Characteristics

## 1.1 Spray Angle

Hydraulic descaling nozzles are normally flat (jet) spray nozzles. The exact definition of the spray characteristics such as spray angle, spray thickness and impact distribution together with the specification of the operation parameters are the first two steps when a spray nozzle is designed. The standardization of descaling nozzles based on the nominal spray angle was introduced many years ago and has proved to be advantageous with regard to header design flexibility and product availability. Four (4) spray angles describing the width of the spray are now very common. These are 22°, 26°, 30° and 40° nozzle tips each available in 13 standard flow sizes (**Table 1**). In order to achieve the above mentioned design flexibility, the spray width is identical for all nozzle tip sizes at identical pressures and spray heights.

Series	Type				Material code	A <sub>o</sub> [mm]	p = 100 bar (1450 psi)		p = 200 bar (2900 psi)		p = 400 bar (5800 psi)	
	Code						[l/min]	[US Gall./min]	[l/min]	[US Gall./min]	[l/min]	[US Gall./min]
	22°	26°	30°	40°								
6S4	495	496	497	498	N3	1.50	12.00	3.17	16.97	4.50	24.00	6.34
6S4	535	536	537	538	N3	1.75	15.00	3.96	21.21	5.60	30.00	7.92
6S4	565	566	567	568	N3	2.00	18.00	4.76	25.46	6.73	36.00	9.52
6S4	605	606	607	608	N3	2.10	23.00	6.08	35.53	9.39	46.00	12.16
6S4	645	646	647	648	N3	2.50	28.00	7.40	39.60	10.46	56.00	14.80
6S4	685	686	687	688	N3	2.80	36.00	9.51	50.91	13.45	72.00	19.02
6S4	725	726	727	728	N3	3.00	45.00	11.89	63.64	16.81	90.00	23.78
6S4	765	766	767	768	N3	3.50	58.00	15.32	82.02	21.67	116.00	30.64
6S4	805	806	807	808	N3	3.80	72.00	19.02	101.82	26.90	144.00	38.04
6S4	845	846	847	848	N3	4.30	89.00	23.51	125.87	33.25	178.00	47.02
6S4	885	886	887	888	N3	4.70	112.00	29.59	158.39	41.85	224.00	59.18
6S4	-	906	907	908	N3	5.00	125.00	33.03	176.78	46.70	250.00	66.06
6S4	-	916	917	918	N3	5.20	134.00	35.40	189.50	50.07	268.00	70.80

**Table 1: Standard flow rates and spray angles Scalemaster series**

## 1.2 Area of Impact and Spray Thickness

The area of impact is a result of the spray width and spray thickness at a given spray height. The spray thickness (also often called spray depth) describes the width in the minor axis of the spray. The spray thickness varies with the spray height as the spray width does, too. Having selected one particular nozzle type the spray width at a given spray height is fixed by the standardized spray angle. The spray thickness however depends predominantly on the internal nozzle design.

## 2. Optimisation of Impact Measurement Technology

The impact distribution over the width and thickness of spray can be measured precisely and documented (**Fig. 2**) as described in great details by my Mr. Stefan Schürman in his paper “Measurement and mathematical approximation of the impact of descaling nozzles” presented during the Hydraulic Descaling Conference in 2000. This tool is essential for the design not only of the nozzles but also for a nozzle arrangement on a header. With spray thicknesses now ranging between only 3 and 5mm at common spray heights and with descaling nozzles sizes becoming smaller and smaller for rolling of thin slabs a new generation of sensors (force transducers) has to be applied providing the accuracy required for the measurement of the impact. A new measurement software for driving the sensor and for documenting the impact distribution was also developed. The sensor must be precisely adjusted under the microscope before taking it to the test facility.

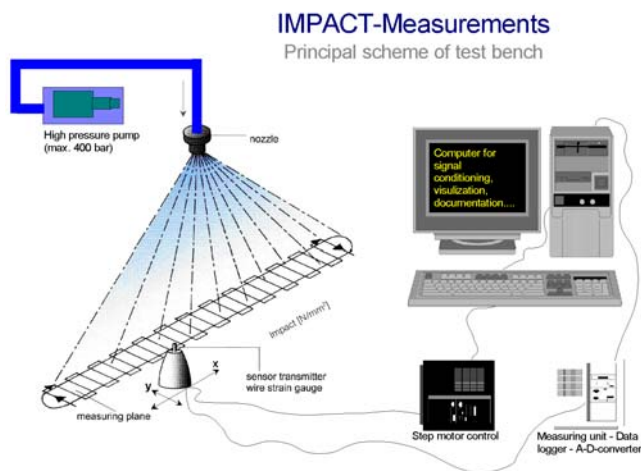

**Fig. 2: Impact measurement facility**

## 3. Design features of conventional Descaling Nozzles

Starting from where the water is entering the nozzle filter stabilizer unit (**Fig. 3 and Fig. 4**) it passes through longitudinal filter slots which are machined into the brass by saw blades leaving a sharp edge behind which is inheritably inevitable and which can be found on all conventional descaling nozzles. The effect of this edge will be discussed later in this paper.

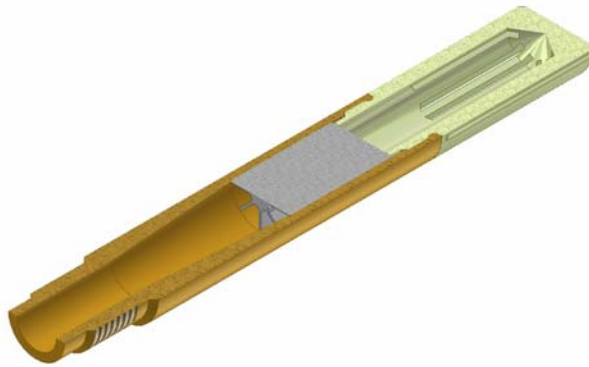

**Fig. 3: Conventional filter/stabilizer unit, inside view**

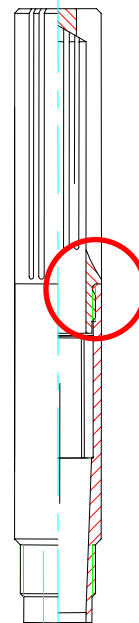

**Fig. 4: Conventional filter/ stabilizer unit with critical machined edge**

The most important part of a descaling nozzle, besides the tip is the stabilizer which is a star-shaped component machined from stainless steel. In any case it has a solid core either with flat surfaces or spikes on each end. The objective of the stabilizer to reduce turbulence and to form a laminar water flow for the nozzle tip.



**Fig. 5: Conventional Scalemaster descaling nozzle having a stabilizer with core and multi component design**

The nozzle tip (**Fig. 5**) consists of the outer body containing the tungsten carbide (TC) insert and, in most cases, a press fit bushing which keeps the TC-carbide insert in place. A gasket in between is also required in this case. Consequently the tip alone can consist of up to four components.

The TC-insert which shapes the spray pattern is manufactured traditionally by pressing and machining the “Green Part” which is sintered afterwards before the final orifice is obtained by grinding with a diamond grinding wheel. Grinding is an

additional process which leaves a very sharp and sensitive orifice edge and also changes the homogeneity of the total surface structure. In most cases Cobalt is used as the TC binder.

#### **4. Main Design features of the new Descaling Nozzle Scalemaster Superior**

Starting with the filter and stabilizer (**Fig. 6**) which are no longer machined traditionally but completely metal injection molded (MIM). Shapes and forms can now be produced economically with these new production technologies which have never been possible with traditional machining by metal cutting. As a result the entire filter stabilizer unit is now a single piece component entirely made from stainless steel giving it a much higher mechanical strength against water hammer. Contact corrosion in case of low PH descaling water no longer can take place at the interface between tip and filter because brass has been completely removed from the nozzle.



***Fig. 6: New Scalemaster Superior filter/stabilizer unit with “core-less” stabilizer and single piece design***

Since the filter slots are no longer cut their lower ends could now be internally shaped with a smooth radius in the water flow direction eliminating most of the turbulences the sharp edge of the old design caused at this point. With additional slots at the filter cap a more homogeneous water flow into the filter is being obtained. The core of the stabilizer, which is no longer a separate component, has now been removed providing the water a free and nearly undisturbed passage and an optimized stabilizing function calming down the already much less turbulent flow after the water has entered through the filter slots.

The nozzle tip (**Fig. 7**) has been completely redesigned. The body material has been changed to pre-tempered high temperature resistant stainless steel giving this component a much higher mechanical strength against water hammer. In this context the slot at the tip front has been replaced by an oval opening for the water jet.

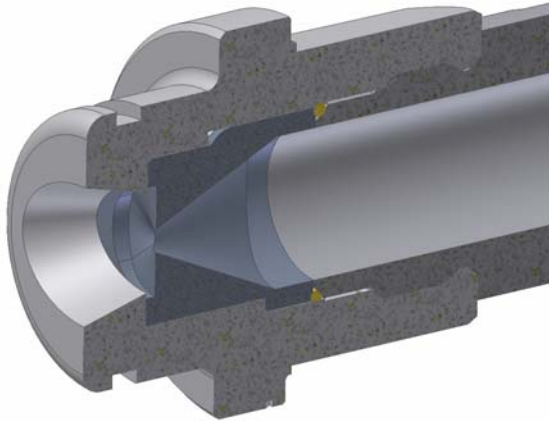

**Fig. 7: New Scalemaster Superior nozzle tip, 2 piece design**

The tungsten carbide insert is also produced by applying metal injection molding (MIM). After sintering no more grinding is necessary because of the high precision which can be guaranteed especially in mass production. A ground breaking new internal shape and orifice geometry was developed for a maximum impact of the spray. The use of Nickel as binder for the tungsten carbide gives a higher chemical resistance against low PH descaling water. The new orifice geometry also reduces nozzle wear and extends the service life.

## **5. CFD – Computational Fluid Dynamics**

Nozzles have been designed by generations of designers by applying empirically gathered data and personal experience by those manufacturing the first prototypes. Achieving identical spray characteristics throughout an entire nozzle family was very difficult and time consuming in the prototyping stage in the past. This was rather a trial and error method with limitations to develop systematic parameter studies since fluid mechanics can be mathematically very complex. A modern discipline, called Computational Fluid Dynamics (CFD), is devoted to this approach by solving fluid mechanics problems and is now successfully applied at Lechler for the development of nozzles and systems.

Computational fluid dynamics (CFD) is one of the branches of fluid mechanics that uses numerical methods and algorithms to solve and analyze problems that involve fluid flows. Computers are used to perform the millions of calculations required to simulate the interaction of fluids and gases with the complex surfaces used in engineering. The most fundamental consideration in CFD is how one treats a continuous fluid in a discretized fashion on a computer. One method is to discretize the spatial domain into small cells to form a volume mesh or grid (**Fig. 8**), and then apply a suitable algorithm to solve the equations of motion. In addition, such a mesh can be either irregular (for instance consisting of triangles in 2D, or pyramidal solids in 3D) or regular; the distinguishing characteristic of the former is that each cell must be stored separately in memory.

With CFD, however we have now an efficient method to produce accurate predictive nozzle geometries for flow analysis and nozzle design as described hereafter.

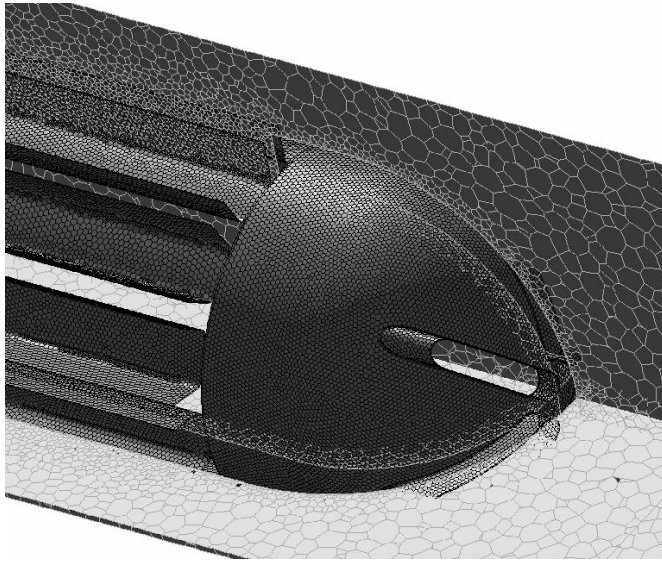

Fig. 8: Typical volume grid of a CFD simulation

## 6. Reduction of nozzle internal pressure loss

**Figure 9** shows how and where up to 7 bars water pressure is being lost inside a conventional descaling nozzle. The coloured areas are representing the water at different pressures. In the red area we have the water at maximum system pressure which extends all the way through the filter slots until shortly in front of the stabilizer. The maximum pressure loss occurs in the slots (light blue colour) of the stabilizer because of the very high water velocity. After the stabilizer in the centre where the velocity is higher, the area with the significantly reduced pressure continues until the nozzle tip orifice. Consequently a pressure drop of 7 bars has to be compensated by a larger tip orifice so that the specified nominal nozzle water flow can be reached.

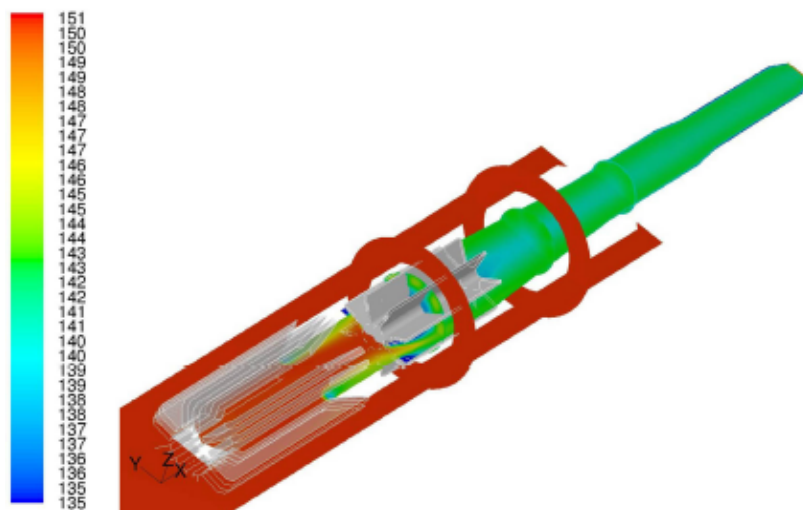

Fig. 9: CFD simulation of a conventional descaling nozzle showing a pressure drop of approx. 7 bars from red to green colour where the nozzle tip is located.

In case of the Scalemaster Superior the pressure drop could have been minimized to an absolute minimum of only 2 bars as shown in (Fig. 10). where the red zone of high pressure extends into the centre of the nozzle tip. Consequently the tip orifice has become smaller compared to a conventional nozzle resulting in a higher exit velocity (speed) of the water. A higher water exit velocity provides also a considerably higher force impacting on the target surface. This was possible due to the optimized internal geometries ranging from filter to TC-insert, the elimination of the stabilizer core and a new tip orifice.

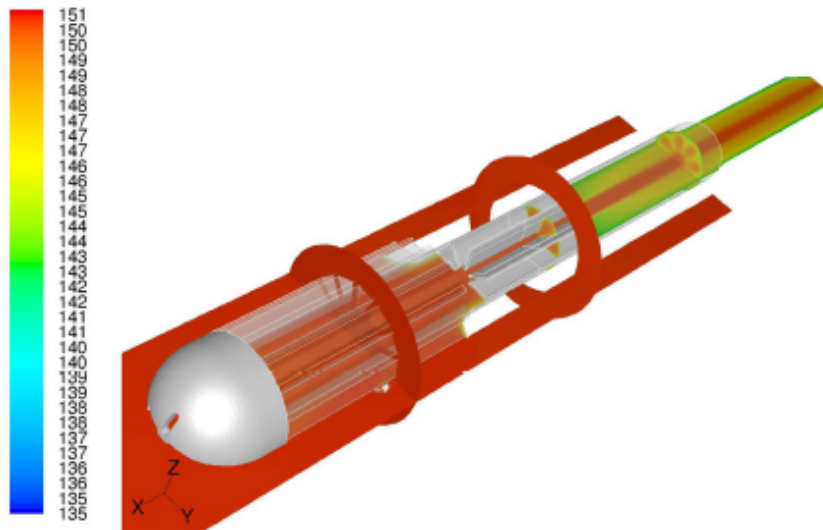
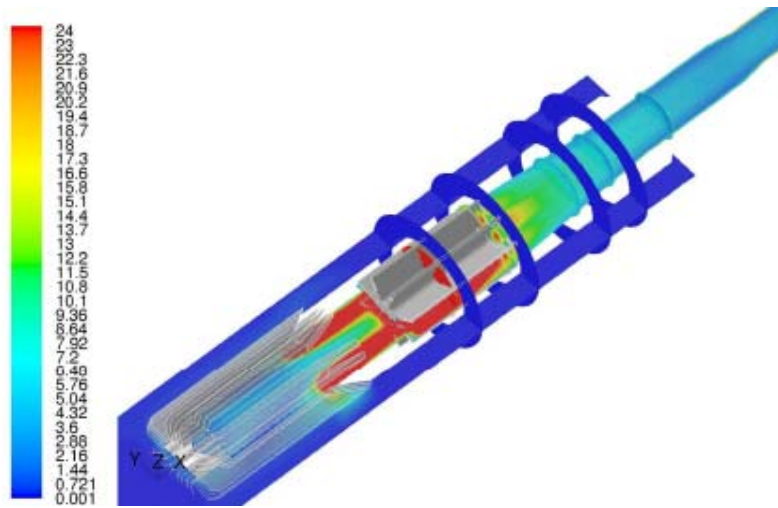

Fig. 10: CFD simulation of a new Scalemaster Superior having a reduced pressure drop of only 2 bars from filter to tip.

## 7. Reduction of nozzle internal turbulences

Figure 11 shows where high kinetic turbulence inside a conventional descaling nozzle occur. The coloured areas represent the water at different degrees of turbulence. In the dark blue areas the water is very calm like in front of the filter and in the welding nipple around the filter. As soon as water enters the filter slots, especially where there are sharp edges left by the saw blade, extremely violent turbulence is introduced (red and yellow colour). This turbulence is maximized further downstream by the core of the stabilizer and extends into the stabilizer slots where they are not reduced. After the stabilizer directly behind its lower core end in a “Dead Zone” again reach high values. Turbulence remains at critical values throughout until the water reaches the nozzle tip orifice.





**Fig. 11: CFD simulation of a conventional descaling nozzle showing a turbulent area in red colour in front, around and behind the stabilizer**

The effect these turbulences have on the spray jet can effectively be demonstrated with a stroboscope. There the highly turbulent movements of the jet in thickness direction can be seen. This increase of the spray thickness caused by a “Dancing jet” also increases the area of impact which subsequently (**Fig. 12**) reduces the impact.

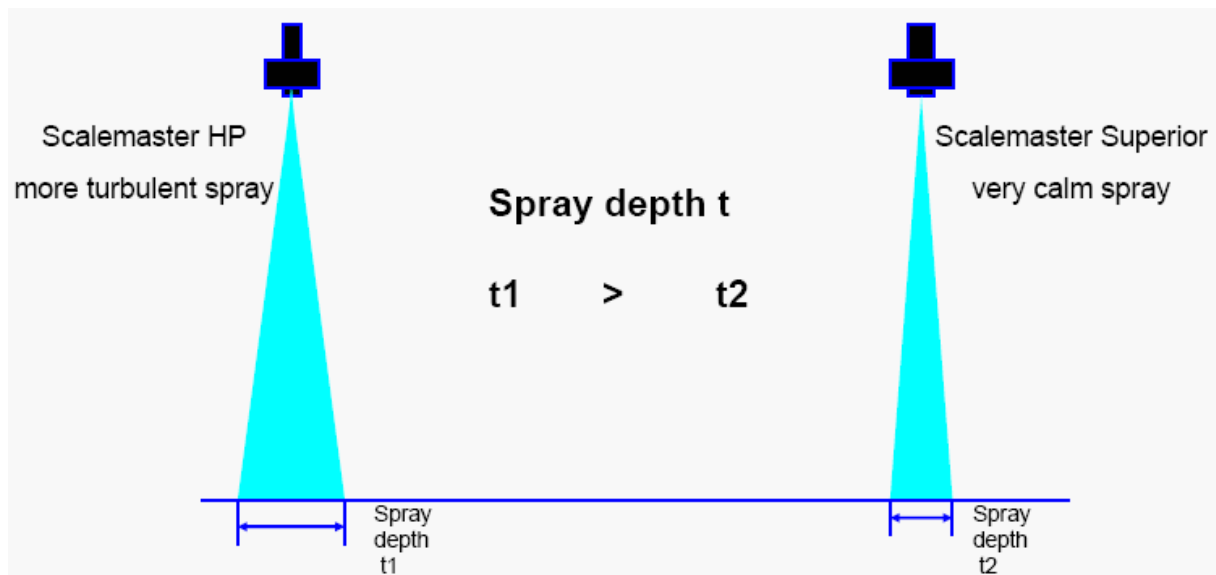

**Fig. 12: Spray thickness (spray depth) comparison**

In case of Scalemaster Superior the internal turbulence of the entire nozzle unit have almost been completely eliminated (**Fig. 13**). This was mainly possible because of the elimination of the major root cause of the turbulence such as the sharp edge at the filter and the stabilizer core. Having eliminated the turbulence the “Dancing jet effect” has also disappeared which helped to reduce the spray thickness and hence the area of impact.

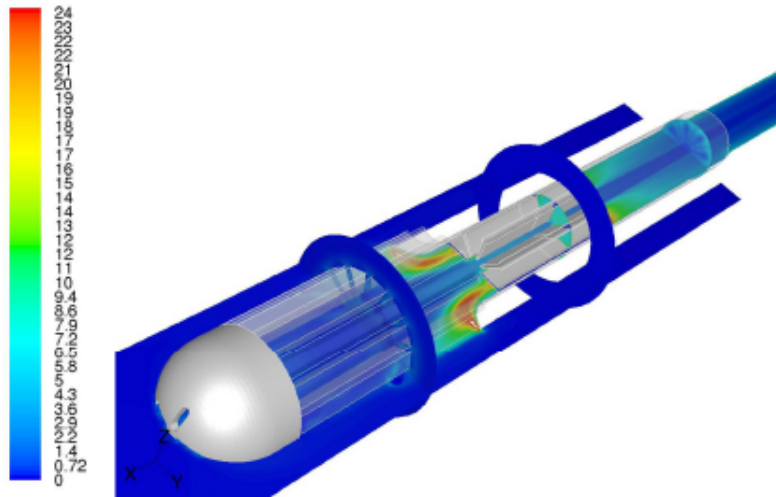

**Fig. 13: CFD simulation of a new Scalemaster Superior having almost no turbulent areas anymore inside the entire nozzle unit**

## 8. Explanation of impact increase of Scalemaster Superior

The two dominating effects which contribute to the increase of impact are the higher water impact velocity and the reduction of the spray thickness. The higher velocity results in a higher force as illustrated in **Formula (1)**. The reduction of the spray thickness means also a reduction of the total spray impact area (spray foot print, Fig. 1). Applying a higher force onto a smaller area results in an increased impact which is shown in **(Fig. 14)** and proven by **Formula (2)**.

$$F = m \cdot a = \dot{m} \cdot v = \dot{m} \cdot \sqrt{\frac{2 \cdot p}{\rho}} \quad (1)$$

$$F = \text{Force} \left[ N = \frac{\text{kg} \cdot \text{m}}{\text{s}^2} \right]$$

$$m = \text{mass} \left[ \text{kg} \right]$$

$$a = \text{acceleration} \left[ \frac{\text{m}}{\text{s}^2} \right]$$

$$\dot{m} = \text{mass flow} \left[ \frac{\text{kg}}{\text{s}} \right]$$

$$v = \text{velocity} \left[ \frac{\text{m}}{\text{s}} \right]$$

$$p = \text{pressure} \left[ \frac{\text{N}}{\text{m}^2} \right]$$

$$\rho = \text{density} \left[ \frac{\text{kg}}{\text{m}^3} \right]$$

### Formula 1

Because spray angles (and therefore spray width) are standardized it's only possible to reduce spray depth in order to concentrate the kinetic energy of the spray on a smaller area.

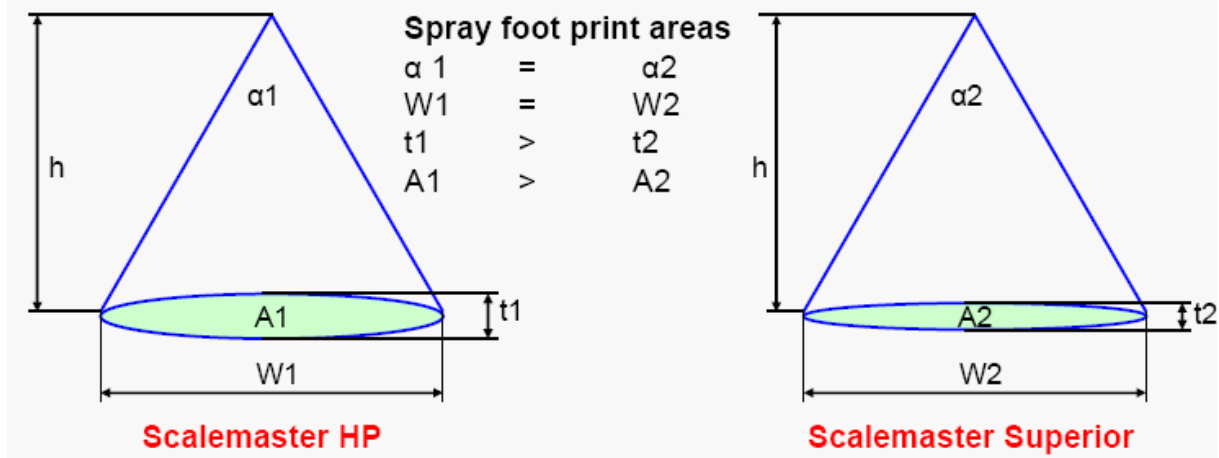

Fig. 14: Spray footprint comparison

$$I = \frac{F}{A} \quad (2)$$

$$I = \text{Impact} \left[ \frac{N}{mm^2} \right]$$

$$F = \text{Force} [N]$$

$$A_{\text{footprint}} = \text{Area} [mm^2]$$

$$F_2 > F_1$$

$$A_{2,\text{footprint}} < A_{1,\text{footprint}}$$

$$I_2 \gg I_1$$

## Formula 2

A scientific approach is necessary to investigate and explain the fluid mechanisms taking place inside the nozzle. This has been the intention up to this point. The impact measurement on a special nozzle test stand has been the preferred and only practical method for the nozzle development, for quality control and comparisons between individual nozzles. As a result a measurement protocol (**Fig. 15**) is being produced indicating all important details of the pre set measurement conditions and the test results in exact figures in 3D format. Only figures and numbers obtained through measurements on the same test stand can really be compared. Test results of two different test stands can not be compared since the sensors, the measurement set points and the calculation and interpretation in the software are certainly not identical. There is no industry standard for measuring impact.

# Spray- Impact- Diagram

Strahl- Kraft- Diagramm



Lechler GmbH  
 Produktionslinie: Tropfenabscheider  
 Ulmer Straße 120  
 D-72555 Metzingen / Germany  
 Telefon: +49(0)7143 962-0  
 Fax: +49(0)7143 962-444  
 E-Mail: info@lechler.de  
 Internet: http://www.lechler.de

Manufacturer (Hersteller) Lechler  
 Product no. (Produktnummer) 6S4.726.N3  
 Accessories (Zubehör) 06S.456.1Y.01.00  
 Customer (Kunde)  
 Date (Datum) 17.04.2008  
 Nozzle state (Düsenzustand) New Sensor size (mm) (Sensorgröße) 1  
 Spray height (mm) (Sprayhöhe) 150 Measurement step (mm) (Messschritt) 1  
 Water pressure (bar) (Wasserdruck) 150  
 Water flow rate (l/min) (Wasserflussmenge) 55  
 Remarks (Bemerkungen) Abnahmemuster

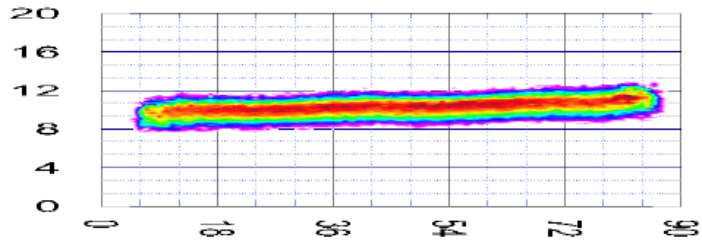

Av. Max Impact [mN/mm<sup>2</sup>] 841,02 Spray Width [mm] 61,8  
 Av. Spray Depth [mm] 3,6 Max. Spray Depth [mm] 4,1

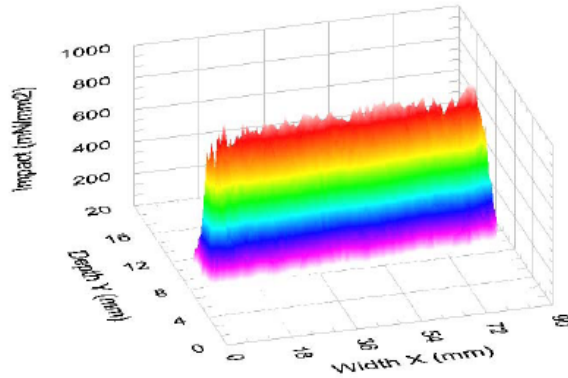
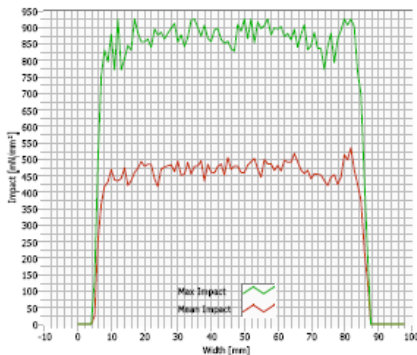

Messung 3402 LPV Nr.  
 Software 1.0.0 Statistik

**Fig. 15: Spray impact measurement protocol of a new Scalemaster Superior having a very uniform impact distribution**

Some time ago in Japan, in the absence of modern 3D measurement technique a simple method was introduced which is the erosion test on aluminum plates. This method does not represent the true operation conditions in a rolling mill since the test spray time needs to be between 3 and 10 minutes whereas in hot rolling the surface remains under the spray for only fractions of a second.

Nevertheless, the erosion test method does also visualize the difference in spray performance as demonstrated in **Fig. 16**. This figure shows the imprint of a Scalemaster Superior (top) and the Scalemaster HP (bottom) on an aluminum plate. The water pressure was 200 bar and the vertical spray height was 150 mm. As described above the Scalemaster Superior concentrates the water on a much sharper spray resulting in a reduced spray thickness, a deeper and more uniform groove.



**Fig. 16: Spray impact erosion comparison, Scalemaster Superior top, Scalemaster bottom**

## **9. User benefits of the new descaling nozzle Scalemaster Superior**

The most significant benefits for the user of the Scalemaster Superior nozzles are:

- The maximum increase of impact at a given flow and pressure has been achieved for a higher surface quality. In average an impact increase of 20% compared to Scalemaster HP is possible when replaced by the same Scalemaster Superior nozzle size.
- Longer service life and higher operation reliability for cost reduction.
- Very even impact distribution of spray for uniform impact distribution across entire surface reduces striping.
- Compatible and interchangeable with earlier Lechler nozzle models, no new spray header required.

## **10. Conclusion**

The successful introduction of surface inspection systems in rolling mills confronted the rolling mills, the mill designers and the nozzle manufacturers with more descaling system issues than ever before, both in terms of surface quality and plant productivity.

The pressure on the steel industry to reduce the energy consumption because of cost reasons and to reduce the emission because of environmental reasons will lead to an intensified search for further potentials for energy savings. In hot rolling the descaling systems have always been in the focus of energy saving programs. This is why the priorities for descaling system upgrades are concentrated on surface quality improvements and on energy saving at the same time.

The increase in impact at identical operation conditions such as nozzle nominal size, spray height and water pressure opens new avenues for the improvements of the descaling performance of the entire system and better surface quality. It also gives us the possibility for further reductions of system water flow and hence which comes along with energy cost savings. To develop and produce even smaller descaling nozzle sizes will now be possible, especially for thin slab rolling mills where the transfer bar from the continuous casting machine is only 50mm to 80 mm thick and where the reduction of temperature loss is a key design objective.

**References :**

- 1.) Schürmann S, Measurement and Mathematical Approximation of the Impact of Descaling Nozzles, Hydraulic Descaling Conference, London 9/2000

