

ENGINEERING
YOUR SPRAY SOLUTION



PRECISION SPRAY NOZZLES

for surface technology

GENERAL INDUSTRY



INNOVATIVE NOZZLE TECHNOLOGY MAKES INNOVATIVE SURFACE TECHNOLOGY POSSIBLE

B

Being successful means making the most of all opportunities that the market offers.



This also includes perfect production processes. Particular importance is attached here to increasing product quality and using more rational production methods. Nozzle and spraying technology offers many different, often surprisingly effective, possibilities of performing such tasks. Lechler can support you in mastering these tasks with an extraordinary potential in terms of experience, ideas and innovative technology.

Whether we're checking the paint on a high-end sedan or how well a dishwasher works – surfaces make or break our first impression of product quality. Along with the quality aspect, surface characteristics are also decisive when it comes to function. One good example: the sophisticated pre-treatment steps in the PCB and photovoltaic industries. But no matter what the sector, all surface treatments include work steps such as cleaning, rinsing, drying, etching, or applying. To achieve optimum results, the required nozzles must be a perfect fit for the respective application.



This demands a high degree of expertise, as well as a broad range of suitable products. Additional knowledge and experience in surface technology applications is particularly helpful, as this simplifies the planning process and enable confident decision-making. What's more, Lechler carefully documents the performance data for all nozzle types – so you can easily access all relevant data in advance.

Surface Technology

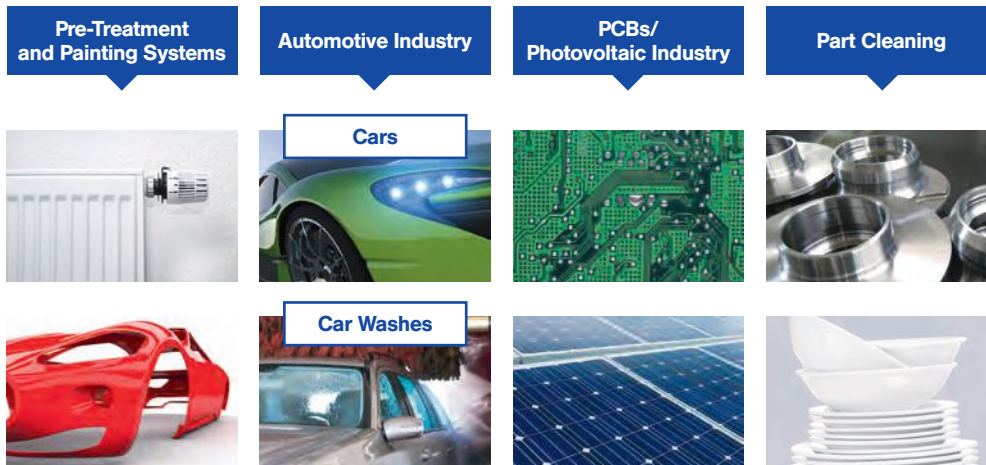

Anything but superficial

Diligence and precision are especially important to success in surface treatment processes. That's why our experts will focus intensively on your task and will bring their expertise and specialist knowledge of the industry to find the best possible result in collaboration with you. At the same time you will benefit from over 140 years of experience in the specialist field of nozzle and spraying technology.

Nozzles for surface treatment

In this brochure you will find Lechler products that are specially tailored to surface technology techniques and that have already proven themselves many times over. Due to their more complex production or smaller production runs, some of these nozzles command higher prices and have longer delivery times. You should bear this in mind in your deliberations and planning. The Lechler standard catalogue also offers you an extensive range of economical and readily available standard nozzles.

Nothing in our range that meets your needs? In that case, please let us know more about what you require so that we can talk to you about the possibility of developing a nozzle that is specially tailored to your needs.

You can rely on the practical experience of our application engineers who have proved their expertise in nozzles and

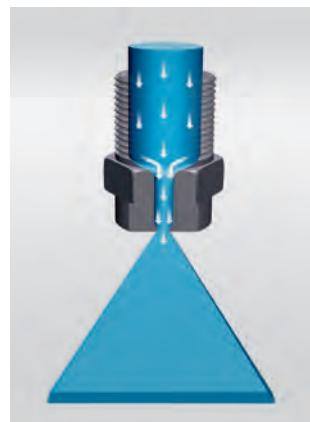

their knowledge of the trade, and have developed many solutions for optimising production processes.

Extensive know-how and excellent technical conditions allow exemplary results to be obtained time after time. Constant research and development work are your guarantee of future-proof solutions.

For detailed and clearly arranged information, visit our website at: www.lechler.de

Content	Page
Applications	
Pre-treatment and painting systems	4–5
Automotive industry	6–7
Cleaning systems	8–9
Photovoltaic and printed circuit boards industry	10–11
Part cleaning	12
Rinsing technology	13
Planning criteria	
14–17	
Products	
MEMOSPRAY®/Easy-Clip 18–23	
Flat fan nozzles	24–34
High-pressure flat fan nozzles	35–36
Tongue-type nozzles	37–39
Full cone nozzles	40–43
High-pressure solid stream nozzles	44
Eductor nozzles	45
Accessories	46–49
Other nozzles	50–51
Online services	
52	

LECHLER NOZZLES ARE AN INTEGRAL COMPONENT IN PRE-TREATMENT AND PAINTING SYSTEMS

Nozzles for water jet cleaning

In pre-treatment and painting systems, water jet cleaning is often employed as an automated process. **Flat fan nozzles and tongue-type nozzles with eyelet clamps** are the main variants used for this. The components pass through several process steps in which they are treated with various fluids. These include, for example, aqueous alkaline solutions and deionised water. **Eductor nozzles** are also used under water, the purpose of which is to prevent sedimentation.

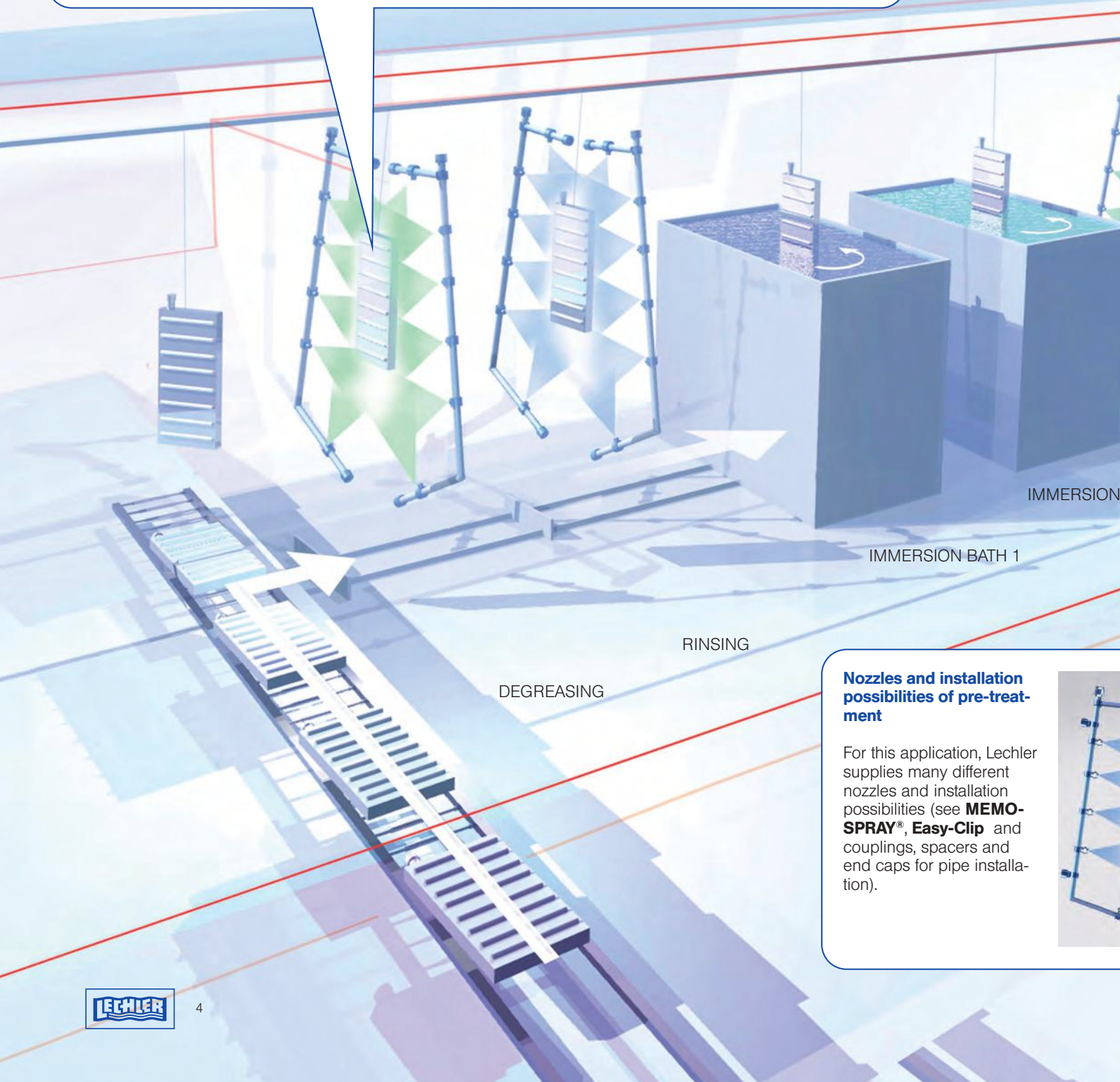
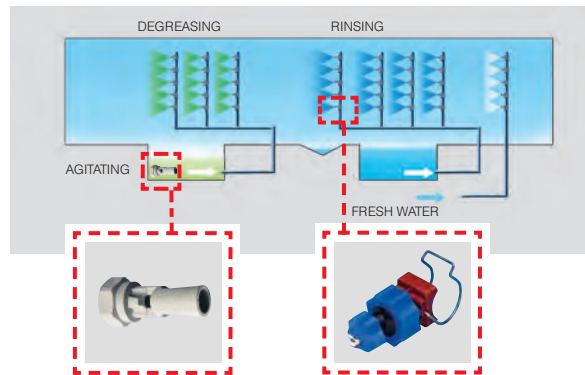

Nozzles and installation possibilities of pre-treatment

For this application, Lechler supplies many different nozzles and installation possibilities (see **MEMO-SPRAY®**, **Easy-Clip** and couplings, spacers and end caps for pipe installation).



Nozzles for the rinsing zone

At the end of a painting line, the components pass through a rinsing zone. There, surplus paint particles that are still mechanically attached are washed off. This is done according to the cascade principle, i.e. in several stages with increasingly clean rinsing agent until deionised water is used.

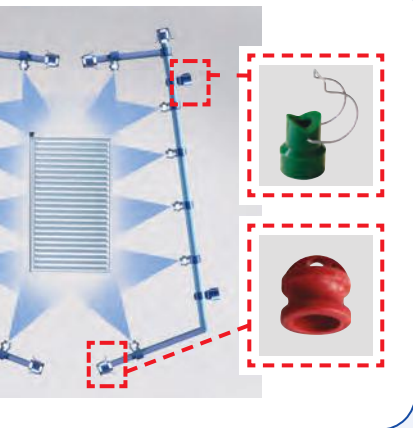
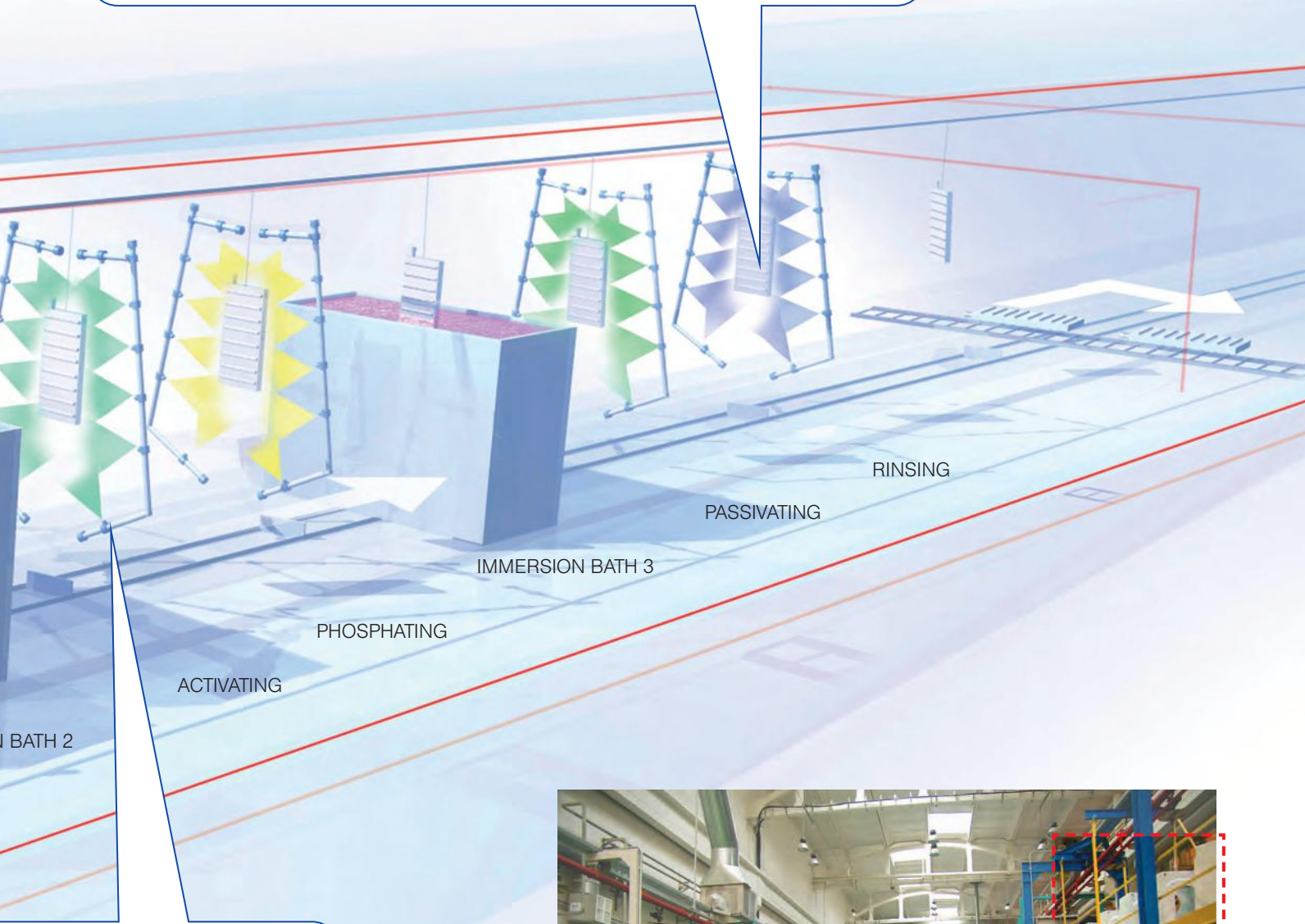
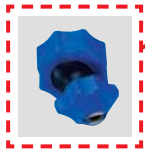

Example of a painting line for washing machine housings. On the left the component before painting, on the right the painting housing exits.

LECHLER NOZZLES ARE USED IN MANY FIELDS IN THE AUTOMOTIVE INDUSTRY

Areas of use from A to Z

- A** Aquaplaning test track spraying
- B** Blowing off dust
- C** Cooling of tools, cleaning of components and parts
- D** Degreasing, dust removal
- E** Electrophoresis washing pipes
- F** Filter cleaning, fire protection, fuel injection
- G** Gas treatment
- H** High pressure deburring and cleaning
- I** Impregnation
- J** Jet cutting
- L** Leak tests (car body leak test), lubrication
- M** Machining centre cleaning
- N** NOx removal
- P** Phosphate treatment
- Q** Quenching
- R** Rain and fog simulation, rain curtains
- S** Salt mist tests (corrosion tests)
- T** Tank cleaning, temperature control
- U** Underbody cleaning
- W** Wet zone with demineralized water, washing between zones
- Z** Zone cleaning (paint spray lines)



Nozzles for tool cooling, tool lubrication and chip removal

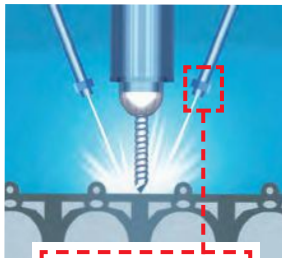

For this task it is crucial that the nozzles spray in the correct location so that the best cooling or lubrication effect is achieved. **Series 676 nozzles** (for example) provide the possibility of adjustment with the aid of a ball joint. In CNC machining centres, **tank cleaning nozzles** that clean the machine's entire interior are also used for chip removal.

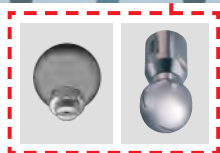

Nozzles for surface pre-treatment



Flat fan nozzles are typically used in many stages of automobile pre-treatment. The **MEMOSPRAY®** and **Easy-Clip** nozzle systems are particularly common.

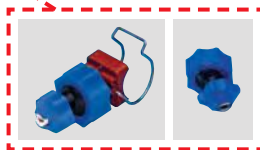

Nozzles for use in washing installations



In this application it is crucial that the nozzles spray in the correct location. Lechler offers a wide range of different **flat fan nozzles**. These also include **high-pressure nozzles** and **tongue-type nozzles**. Selecting the correct nozzle enables the cleaning result and water consumption to be balanced.



Nozzles for leak testing

Before they are delivered, cars must be checked to ensure that they are well sealed against rain and moisture. This involves spraying them from all sides using **full cone** and **flat fan nozzles**. Here the rain intensity settings range from gentle rain have to pass through a car wash.

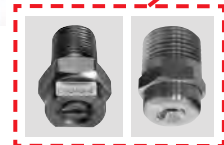

CLEANING SYSTEMS ARE FITTED WITH LECHLER FLAT FAN AND TONGUE-TYPE NOZZLES

Nozzles for the pre-wash

The purpose of the pre-wash is to soften the soil. **Flat fan nozzles** or **tongue-type nozzles** with a wide spray angle and a low flow rate are preferred.

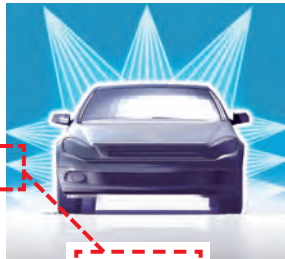

Nozzles for the main wash

The main wash requires high-impact flat fan nozzles or tongue-type nozzles. The spray angle should be 30 to 45 degrees. Their sharp jet means that tongue-type nozzles are ideally suited to the low pressure.

High-pressure flat fan nozzles differ from low-pressure nozzles by virtue of their hardened nozzle mouthpiece, which gives these nozzles a longer service life.

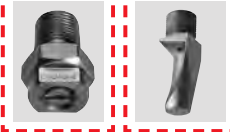
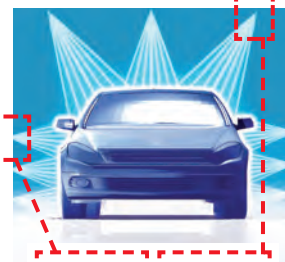

Nozzles for sill and wheel washing

The lower third of the vehicle is mostly where soil is found (e.g. impacted insects). A high impact is crucial to removing this type of soil. We recommend **high-pressure nozzles** with a narrow spray angle.

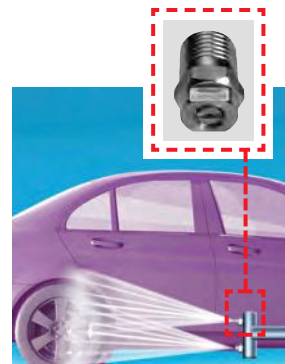

Nozzles for applying wax

Wax should be applied as evenly as possible. This requires a defined nozzle arrangement. For this we recommend our **series 652 in conjunction with a retaining nut and eyelet clamp**.

Manifolds fitted with this series distribute the water very evenly.

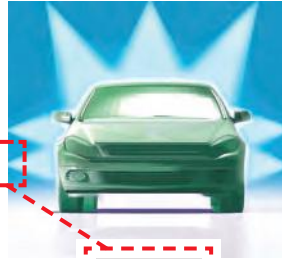

Nozzles for rinsing

Rinsing is the last stage before drying. This requires small droplets that run off the vehicle quickly. **Flat fan nozzles** with a very low flow rate are used in most cases.

The nozzles are easy to align in conjunction with a **bayonet cap** and a **ball joint**.



Arrangement of low-pressure flat fan nozzles

Lechler **flat fan nozzles** give you a linear impact with even droplet application. A prerequisite for this is that the spray widths B overlap by approximately $1/3-1/4$. Here the nozzles should be aligned approximately $5-15^\circ$ to the pipe's longitudinal axis in order to prevent the sprays from being interrupted.

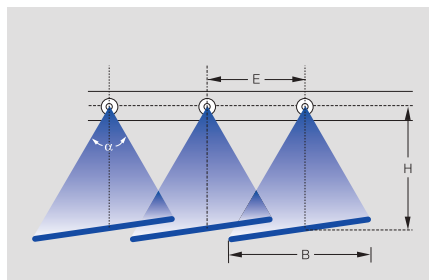

LECHLER NOZZLES ARE USED IN MANY FIELDS IN THE PHOTOVOLTAIC AND PRINTED CIRCUIT BOARDS INDUSTRY

Rotating cleaning nozzles for printed circuit board manufacture

Rotating cleaning nozzles for printed circuit board manufacture **series 500.191. Rotating cleaning nozzles** are used in horizontal continuous through-put systems for printed circuit board manufacture. The nozzles are made entirely of PVDF, which makes them optimally suited for use in sulphuric acid-based applications.

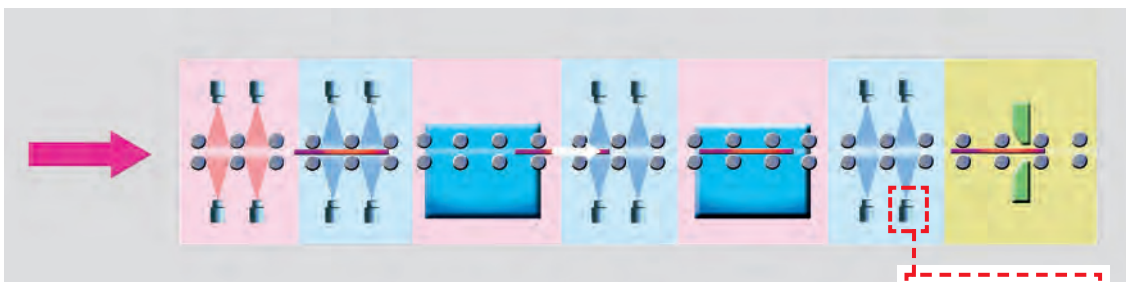
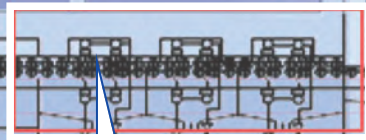

Nozzles for alkaline texturing

Flat fan nozzles in several series-connected modules are used in this process. Nozzles made of PVDF are preferred, because they are resistant to the chemicals used.



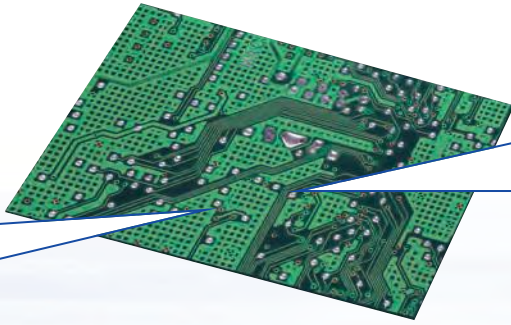

Circuit board manufacturing

Developing, etching, stripping. In a typical inner layer line for manufacturing circuit boards, the resist is developed in the developer, the bare copper is sprayed with an acidic etching solution in the etching module and is removed down to the base material, and the resist is stripped off by using an alkaline solution. This involves the use of many types of nozzles that

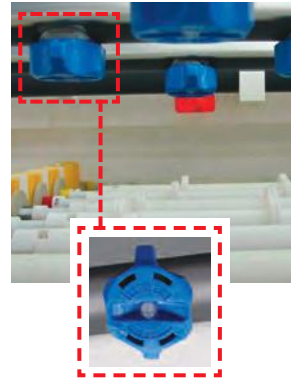

are already familiar, such as **series 646 bayonet quick-locking system**.

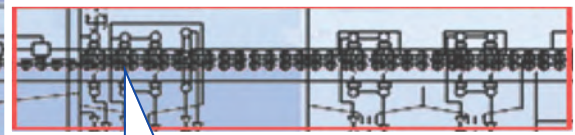

Wafer cleaning

After the sawing process, the wafers are gently cleaned with **full cone nozzles**. The cleaning medium is sprayed onto the individual wafers, thereby achieving a homogeneous cleaning result across the entire surface.

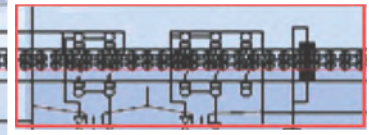
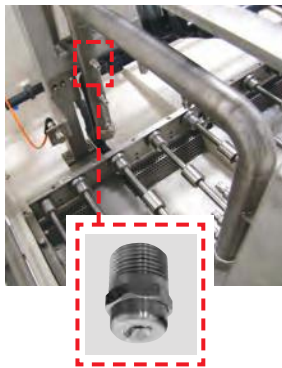

Nozzles for wafer moistening

After the sawing process, the wafers are moistened with hollow cone nozzles. **Hollow cone nozzles** produce a fine spray mist that settles on the wafers. This ensures that no impurities dry onto the wafer, thereby also ensuring an efficient wafer production process.

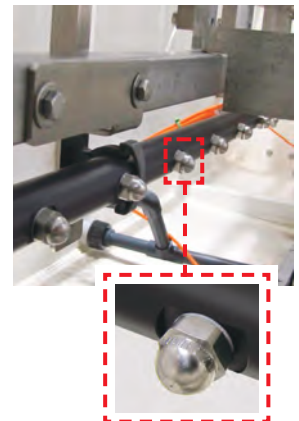

PART CLEANING WITH LECHLER FLAT FAN NOZZLES AND TONGUE-TYPE NOZZLES

Cleaning engine pistons

Dual-lane continuous cyclic cleaning system for cleaning aluminium engine pistons. Increasing volumes require efficient and reliable nozzles. **Series 612 nozzles** can be used if only a small installation space is available at the same time.

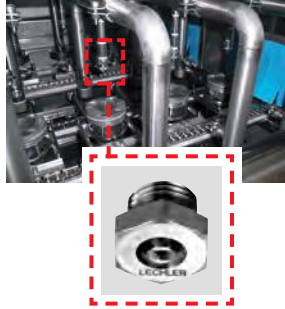

Oil sump cleaning

Continuous cleaning system for aluminium oil sumps, four-sided spraying.

Simple installation and quick replacement of nozzles enable the system's maintenance costs to be reduced.

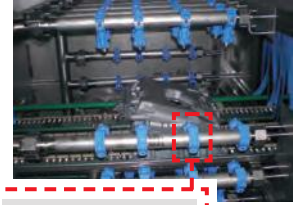

Deburring

High-pressure water jet-deburring aided by a robot. A notable feature of **flat jet nozzles** is a very shallow jet depth, giving them a particularly high cleaning effect.

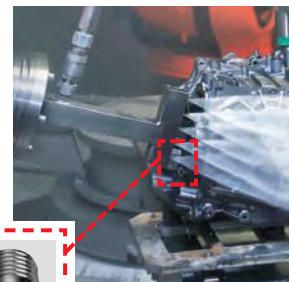

PROFESSIONAL RINSING TECHNOLOGY WITH LECHLER NOZZLES

Cleaning oven racks

Washing system for cleaning oven racks used in bakeries, for example. **Series 612 PVDF flat fan nozzles for pressing into pipes** and **series 632 stainless steel flat fan nozzles with a retaining nut and eyelet clamp** are used to spray the cleaner onto the racks in foam form. The nozzles are used for rinsing clean in a downstream process.



Conveyor belt dishwashers

Lechler series 612 PVDF flat fan nozzles for pressing into pipes are used for fresh-water rinsing in conveyor belt dishwashers in order to remove any remaining suds from the objects being washed. This requires homogenous water distribution in order to achieve an optimum and constant cleaning result.

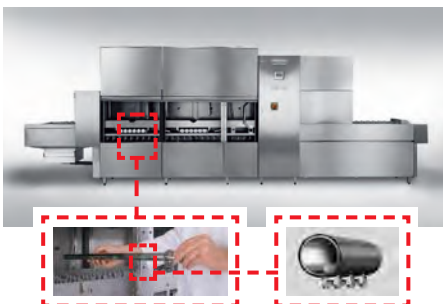

WHAT YOU SHOULD KEEP IN MIND WHEN PLANNING

The most important criteria that must be taken into account when selecting nozzles are listed below.

① Impact

The force of impact when using of a liquid jet on a surface plays an important role in surface technology. The ratio of the force (F) to the surface (A) is referred to as the impact (I).

$$I = \frac{\text{Impact force}}{\text{Impact surface}} = \frac{F}{A} \left[\frac{\text{N}}{\text{m}^2} \right]$$

The following explains the parameters with which the impact can be influenced.

Impact surface and spray angle

The impact surface is the area where the droplet strikes. The smaller the surface area, the greater the impact values. Nozzles with high impact are, for example, solid stream nozzles and flat fan nozzles with a narrow spray angle.

Pressure

Increasing the connected pressure results in an increase in the spray impact. Doubling the pressure while maintaining the same flow rate results in a doubling of the impact.

Flow rate

Increasing the flow rate by using a larger nozzle increases the impact, assuming that the other parameters (spray angle, pressure and medium) remain the same.

Nozzle selection criteria:

- ① **Impact**
 - Impact surface and jet shape
 - Spraying distance
 - Pressure
 - Flow rate
 - Jet depth
- ② **Spray angle and spraying behaviour**
- ③ **Liquid distribution**
- ④ **Droplet sizes**
- ⑤ **Factors influencing the temperature behaviour of nozzle materials**
- ⑥ **Material and wear**

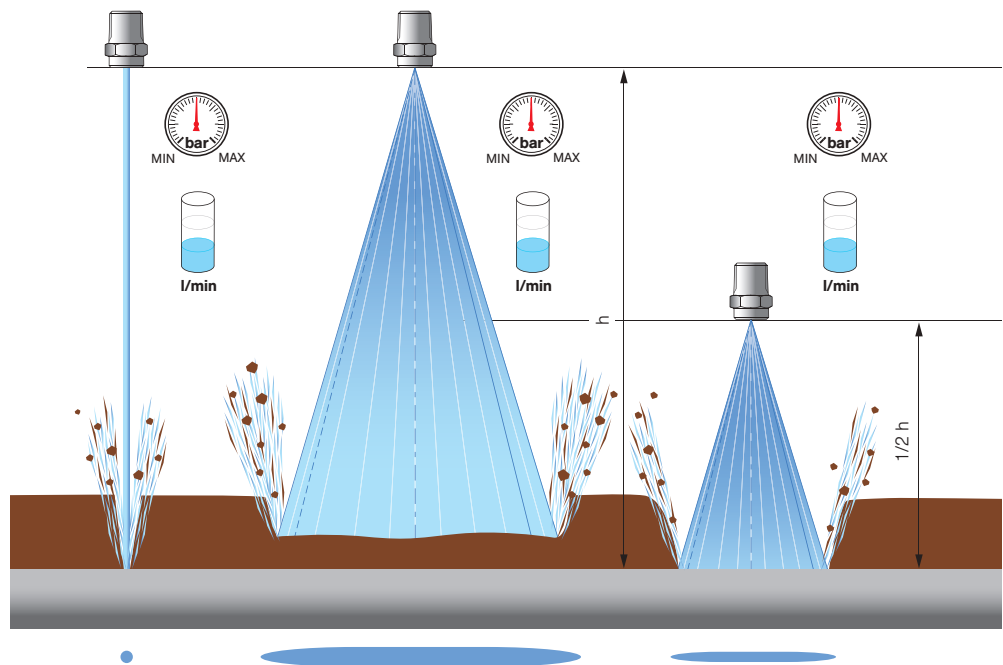

Comparison of the cleaning result of three nozzles with identical pressure and flow rate.

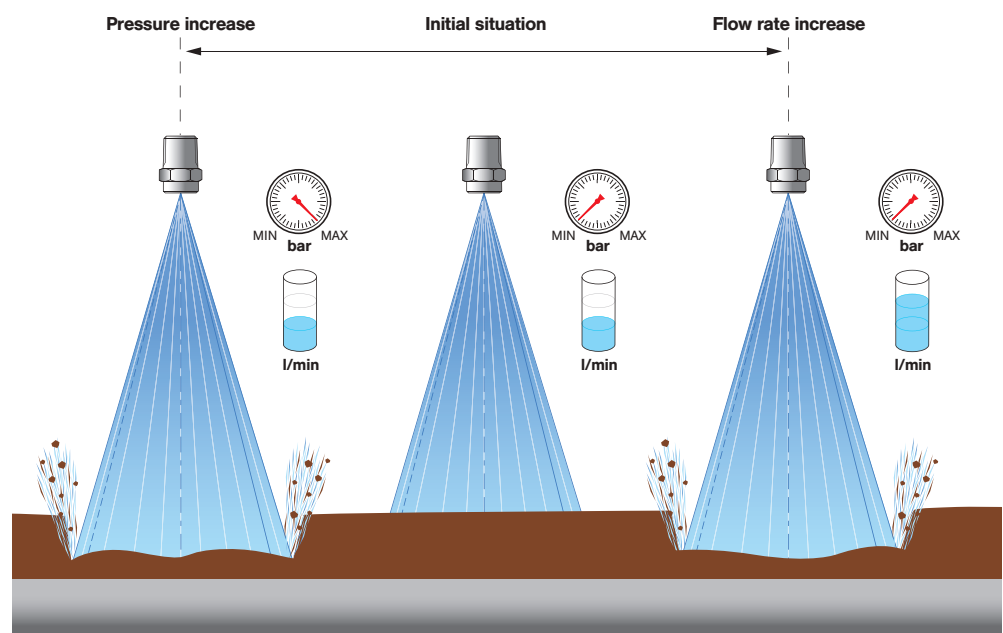

Comparison of the cleaning result of three nozzles with pressure or flow rate increase.

Spraying distance (vertical distance to the nozzle)

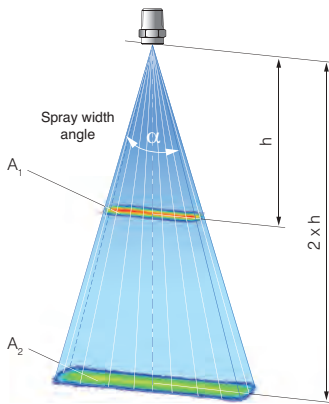

With a flat fan nozzle, doubling the distance would ideally result in a quadrupling of the surface area sprayed.

Theoretically, for atomization nozzles, the greater the distance the greater also the surface area sprayed, resulting in the impact being reduced accordingly.

The spray angle and jet depth ensure that the sprayed surface area becomes larger as the spraying distance increases.

In theory, the following applies to flat fan nozzles: If the spraying distance is doubled, the sprayed surface area quadruples. Consequently, the impact decreases four-fold.

Spray depth

When flat fan nozzles are used, the impact that can be achieved depends greatly on the quality of the spray. For example, using special jet geometries (Lechler high-pressure flat fan nozzles) or a high flow quality, a narrower spray depth can be obtained.

Assuming that the other parameters (pressure, flow rate, spray angle and medium) remain the same, a narrower spray depth results in a higher impact.

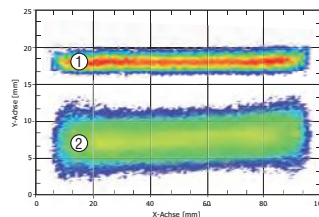
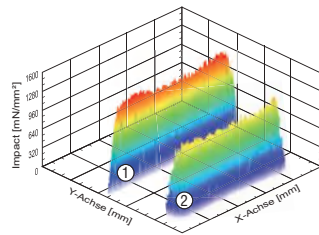

Comparison of the spray depth of a high-pressure flat fan nozzle ① with a standard flat fan nozzle ②

Distance	Area	Impact
h	A	I
1.5 x h	2.25 x A	I / 2.25
2 x h	4 x A	I / 4
3 x h	9 x A	I / 9
4 x h	16 x A	I / 16

② Spray angle and spraying behaviour

Depending on the version and job, single-fluid nozzles are available with differently stepped spray angles from 0° (solid jet nozzles) to 360° (tank-cleaning nozzles). The spray angles quoted by Lechler apply close to the nozzle and in a still atmosphere. Gravity and flow processes in the ambient atmosphere alter the spray pattern. Depending on the version, single-fluid nozzles can spray the liquid as a hollow cone, full cone or flat fan.

The solid jet nozzle does not spray, but rather produces a closed jet that hits at a concentrated point. The jet only begins to break up after some distance. Twin-fluid nozzles have a narrow spray angle of approximately 20° due to the high speed at which the compressible medium exits. However, as the distance from the nozzle increases, the spray pattern becomes increasingly less sharply defined. Twin-fluid nozzles normally produce full cone or flat fan spray patterns, and some versions can be changed over accordingly.

Height of the nozzle position

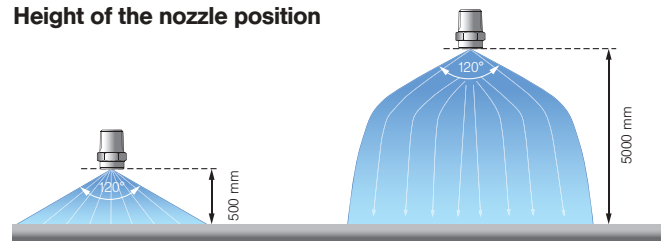

The diagram above illustrates how height influences the spray pattern.

Changing the nozzle pressure

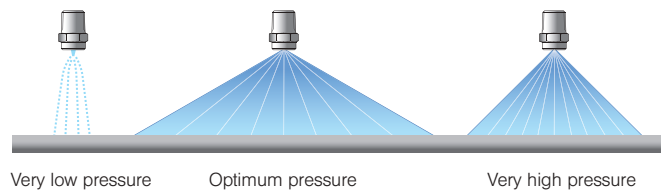

Spraying direction

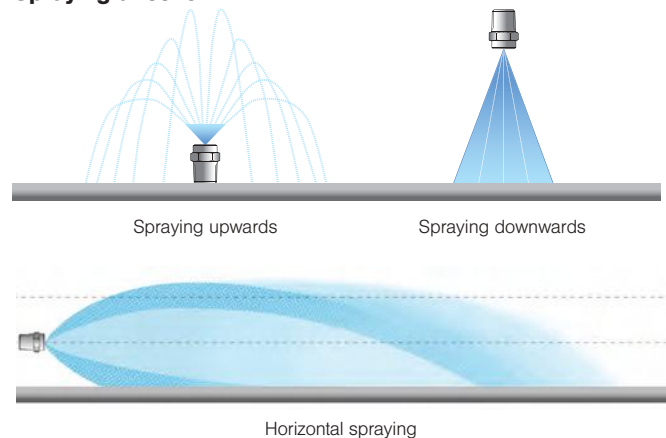

WHAT YOU SHOULD KEEP IN MIND WHEN PLANNING

③ Liquid distribution

In coating processes, for example, it is attached to the homogenous distribution of the sprayed liquid. In order to obtain an even liquid distribution, several nozzles must be arranged next to each other because one nozzle alone would produce a parabolic liquid distribution as standard. The arrangement of several nozzles enables an almost even distribution to be obtained by overlapping.

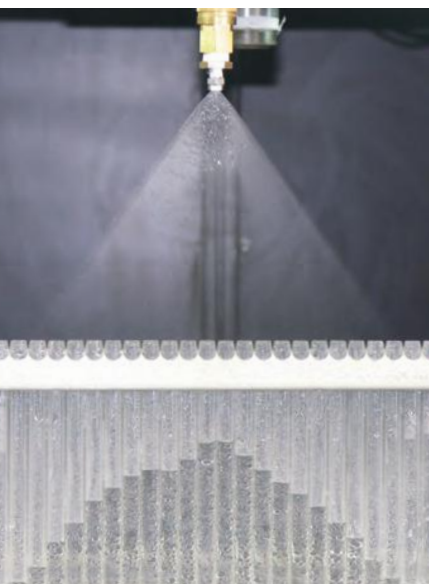

Measuring the distribution

The liquid distribution in a measuring plane is determined by collecting the volume of liquid in a combination of Plexiglas cylinders. The filling level of the individual cylinders is determined completely automatic. This measuring process is also suitable for recording the liquid distribution of a nozzle across a moving measuring plane. This enables conveyor belt spraying to be simulated, for example.

④ Droplet sizes

Twin-fluid nozzles can produce very fine to extremely fine droplets, this being mainly dependent on the flow rate ratio of the compressible medium being used (m^3/h) to the atomized liquid (l/min). The greater this ratio, the finer the atomization. In the case of single-fluid nozzles, the droplet spectrum is determined primarily by the pressure, the nozzle design and the flow rate. Increasing pressure results in finer atomization, but mostly only up to a certain level.



Provided that the pressure and flow rate are the same, hollow cone nozzles produce very fine to fine droplets, full cone nozzles produce somewhat coarser droplet spectrums and flat fan nozzles have the coarsest droplet spectrum. If we compare nozzles of one series at a particular pressure, nozzles with a lower flow rate produce finer droplet spectrums than nozzles with a higher flow rate.

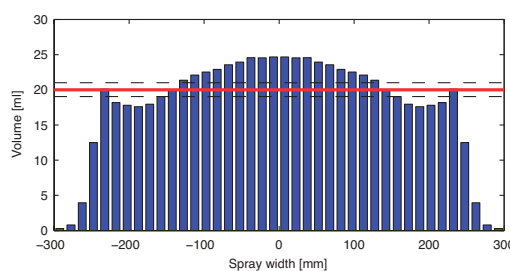

Liquid distribution of a Lechler high-pressure flat fan nozzle.

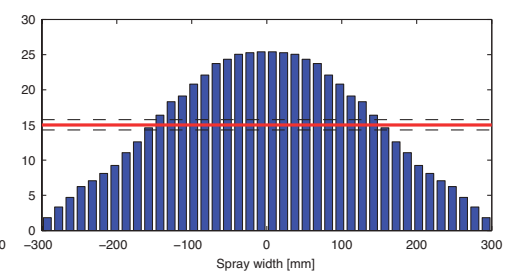

Liquid distribution of a Lechler standard flat fan nozzle.

⑤ Factors that influence the temperature behaviour of nozzle materials

A distinction must be made here between low-temperature behaviour and high-temperature behaviour. Applications with temperatures up to $140^\circ C$ are very common, because this is the range within which for example most cleaning applications and sterilisation processes fall. Applications with higher temperatures are rare, and applications at very low temperatures are even more rare.

The general temperature information from material data sheets must always be scrutinised for every single

case of nozzle use. The main factors that influence the suitability of a nozzle material at higher temperatures are: Pressure and the associated mechanical stress type along with chemistry and time. Chemical processes can be more aggressive at high temperatures. A material may be able to withstand them if this temperature occurs for a short period only. In all materials, high temperatures result in reduced strength values. The mechanical stress type must therefore also be taken into account in high-pressure applications, in particular. In addition, vibrations in the system can cause premature failure.

Chemistry (accelerated by high temperatures)

Pressure and mechanical stress (e.g. vibrations)

Temperature behaviour of nozzle materials

Time (permanently high temperatures)

⑥ Material and wear

Nozzle wear depends primarily on the conditions of use and the nozzle material. Normally, the nozzle's liquid discharge opening wears as a result of material abrasion. The following conditions of use can speed up wear:

- Operating the nozzle above the recommended pressure range
- Solids in the liquid and also hard particles
- The use of chemically aggressive substances (see figure)

The nozzle body can also wear from the outside if the nozzle is used in a harmful environment (corrosive gases, radiation, temperature).

The diagram below shows the factors that influence nozzle wear.

Signs of nozzle wear

Nozzle wear becomes apparent from a noticeable increase in flow rate. The cause of this is the enlarged cross section of the liquid opening that results from material abrasion. This means that if a pressure is permanently set, more liquid is discharged than it was originally intended. The result of this is higher fresh water and waste water costs.

Fig. 1 shows an example of a heavily corroded spray ball.

Material wear

In most cases, excessive wear can be counteracted by selecting a different material. One of the most common cases is the atomization of a liquid with a solid component. Such particle-laden liquids cause significant wear if the particles have a greater hardness than the nozzle material (Fig. 2). The table shows different materials and their average Vickers hardness. The values are for the purpose of rough estimates only.

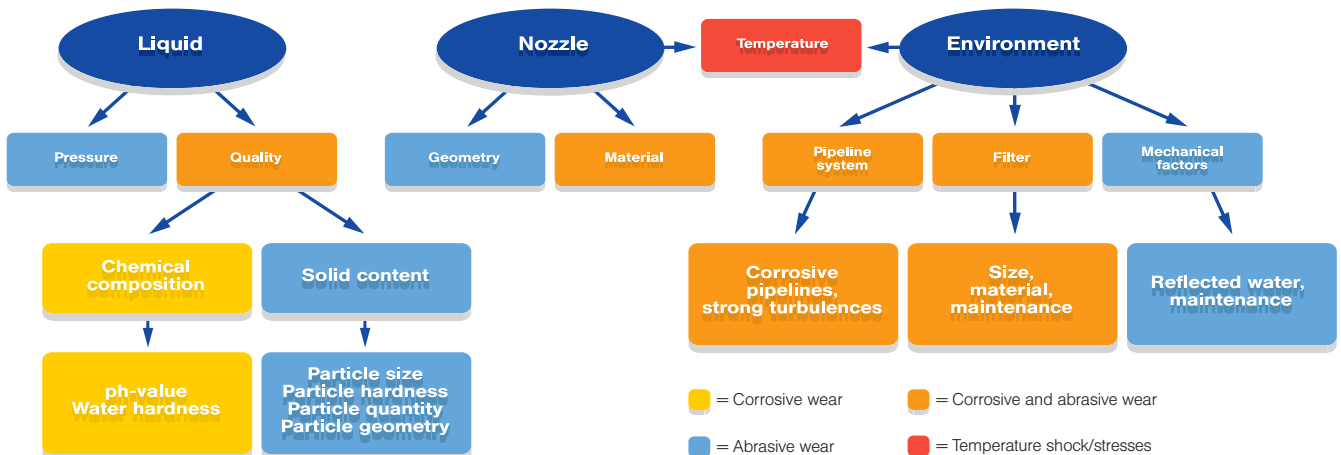

Fig. 1: Chemical corrosion of a spray ball



Fig. 2: Wear of a full cone nozzle ball

Nozzle material	Vickers hardness (HV)
Aluminium	~ 80
Brass	80–150
Titanium (grade 1 to 4)	125–210
Alloy 22	200–250
Stainless steel	220–270
Stainless steel (hardened)	390–690
Carbide	1000–2300
Ceramic	1500–2700
Sapphire/ruby	~ 2300



Factors that influence nozzle wear.



Nozzle systems for surface treatment

MEMOSPRAY®/Easy-Clip



MEMOSPRAY®/Easy-Clip combination

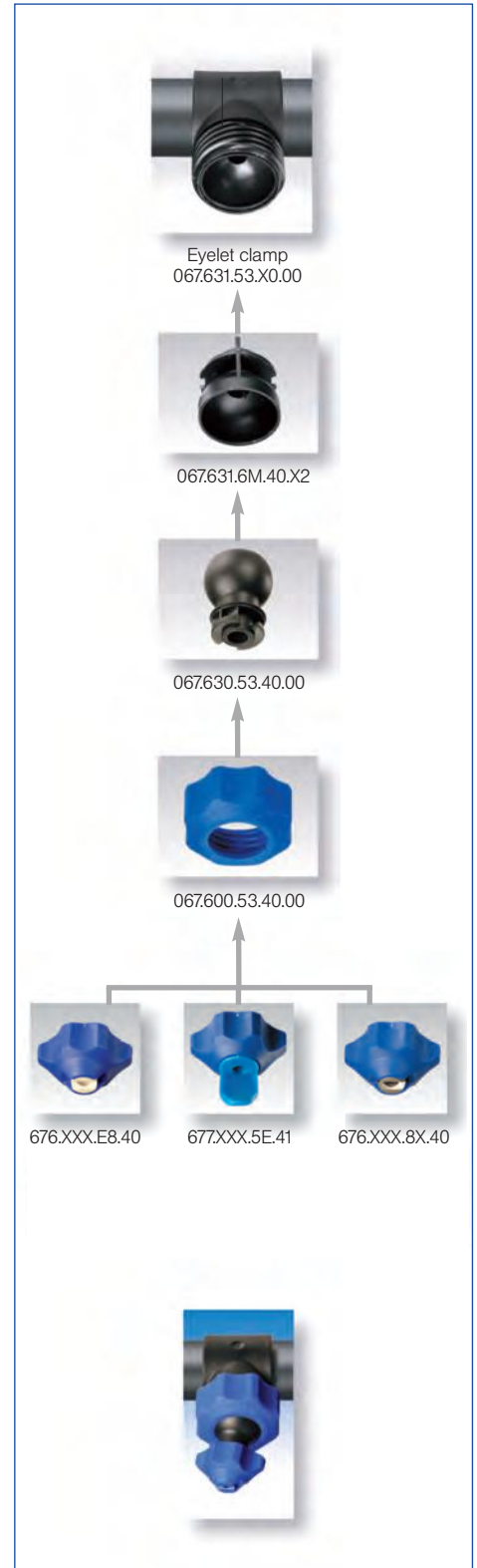
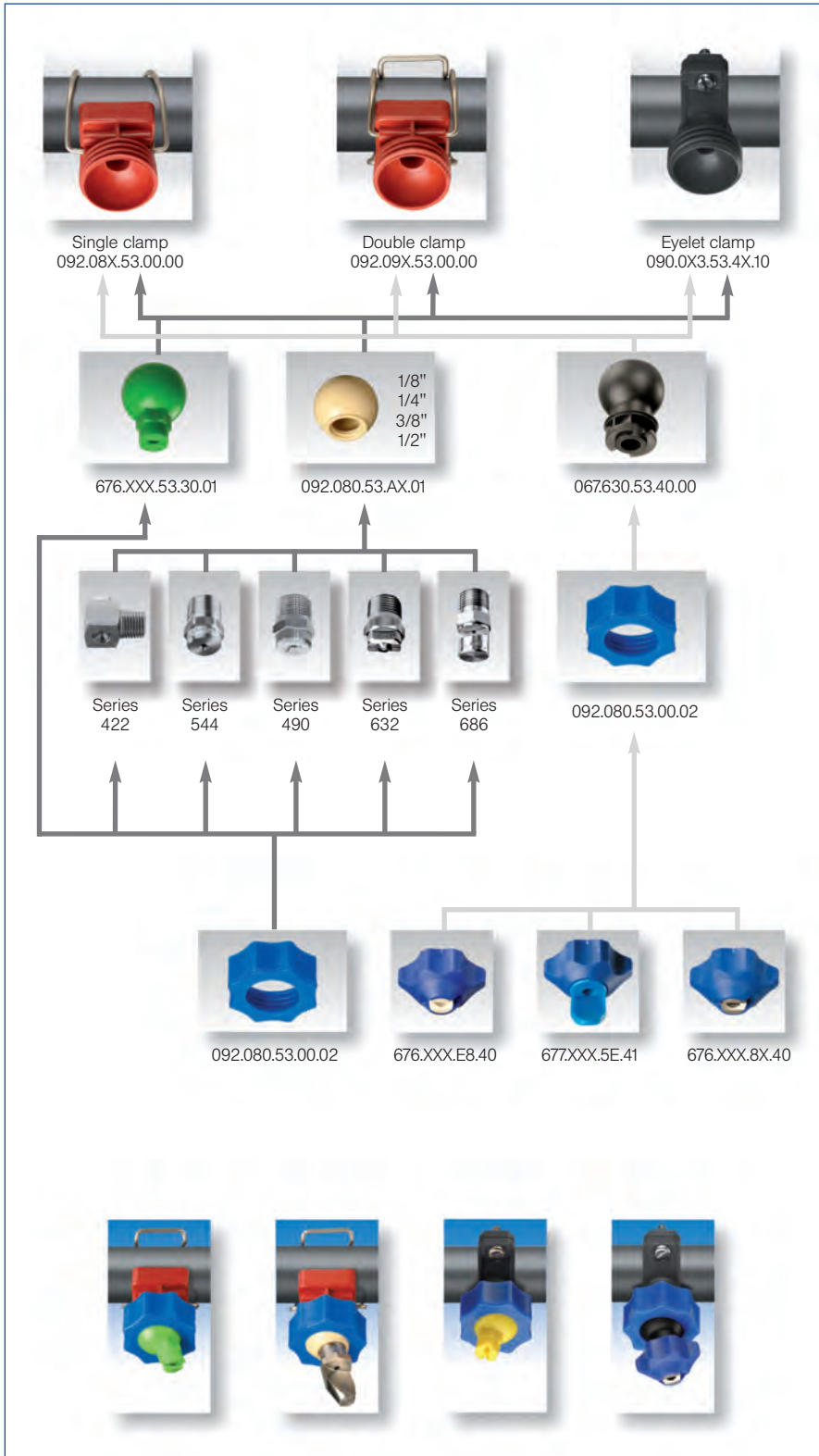



Nozzle systems for surface technology

MEMOSPRAY® nozzle system



Maintaining of the adjusted spray direction by the »memory effect«. Very easy handling without the need for special tools.

Especially pressure resistant pipe connector.

Application:

Degreasing, phosphating in surface treatment, cleaning.

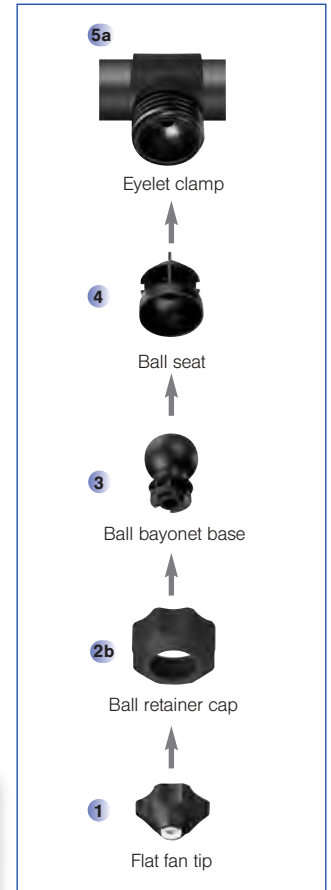
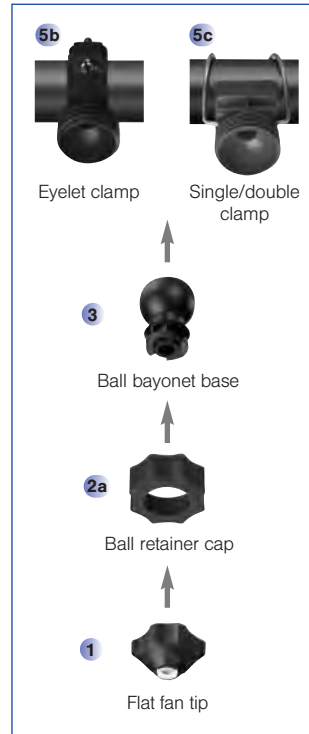
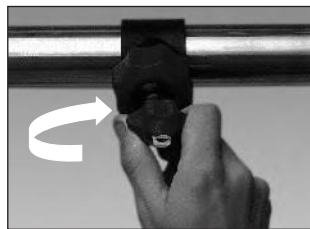
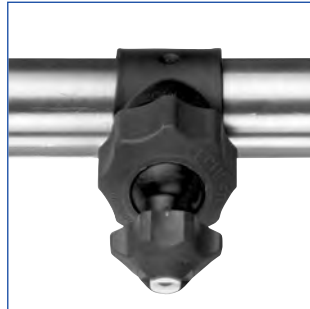

Type	Ordering no.	Material				E Ø [mm]	Flow rate [l/min] bei p [bar]					Weight [g]					
		8F	8R	E8	53		1.0	1.5	2.0	2.5	5.0	PP/303 SS	PP/316L SS	PP/Ceramic	PP		
		Housing: PP Insert: 303 SS	Housing: PP Insert: 316L SS	Housing: PP Insert: ceramic	Polypropylene (PP)												
1 Flat fan nozzle	30°	676.642.xx.40	○	○	-	-	1.6	2.83	3.46	4.00	4.47	6.33	15	15	-	-	
	30°	676.722.xx.40	○	○	-	-	2.1	4.46	5.46	6.30	7.04	9.96	15	15	-	-	
	30°	676.762.xx.40	○	○	-	-	2.3	5.66	6.93	8.00	8.94	12.65	15	15	-	-	
	30°	676.802.xx.40	○	○	-	-	2.6	7.07	8.66	10.00	11.18	15.81	15	15	-	-	
	30°	676.842.xx.40	○	○	-	-	3.0	8.84	10.82	12.50	13.97	19.76	15	15	-	-	
	30°	676.882.xx.40	○	○	-	-	3.4	11.31	13.86	16.00	17.89	25.30	15	15	10	8	
	30°	676.922.xx.40	○	○	-	-	4.1	14.14	17.32	20.00	22.36	31.62	15	15	10	8	
	30°	676.962.xx.40	○	○	-	-	4.2	17.68	21.65	25.00	27.95	39.53	15	15	10	8	
	30°	677.002.xx.40	○	-	-	-	4.7	22.27	27.28	31.50	35.22	49.81	15	-	-	-	
1 Flat fan nozzle	60°	676.644.xx.40			-	-	1.6	2.83	3.46	4.00	4.47	6.33	15	15	-	-	
	60°	676.724.xx.40			-	-	2.1	4.46	5.46	6.30	7.04	9.96	15	15	-	-	
	60°	676.764.xx.40			-	-	2.3	5.66	6.93	8.00	8.94	12.65	15	15	-	-	
	60°	676.804.xx.40			-	-	2.6	7.07	8.66	10.00	11.18	15.81	15	15	-	-	
	60°	676.844.xx.40			-	-	3.0	8.84	10.82	12.50	13.97	19.76	15	15	-	-	
	60°	676.884.xx.40			-	-	3.4	11.31	13.86	16.00	17.89	25.30	15	15	10	8	
	60°	676.924.xx.40			-	-	4.1	14.14	17.32	20.00	22.36	31.62	15	15	10	8	
	60°	676.964.xx.40			-	-	4.2	17.68	21.65	25.00	27.95	39.53	15	15	10	8	
	60°	677.004.xx.40			-	-	4.7	22.27	27.28	31.50	35.22	49.81	15	15	10	8	
	60°	677.044.xx.40			-	-	5.5	28.28	34.64	40.00	44.72	63.25	15	15	-	-	
60°	677.084.xx.40			-	-	6.2	35.36	43.30	50.00	55.90	79.06	15	15	-	-		

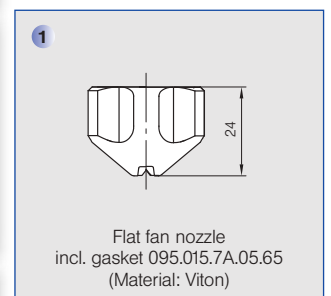

Continued on next page.

Conversion formula for the above series: $\dot{V}_2 = \dot{V}_1 \cdot \sqrt{\frac{p_2}{p_1}}$



Nozzle systems for surface technology

MEMOSPRAY® nozzle system



Type	∠	Ordering no.	Material				E Ø [mm]	Flow rate [l/min] at p [bar]					Weight [g]					
			8F	8R	E8	53		1.0	1.5	2.0	2.5	5.0	PP/303 SS	PP/316L SS	PP/Ceramic	PP		
			Housing: PP Insert: 303 SS	Housing: PP Insert: 316L SS	Housing: PP Insert: ceramic	Polypropylene (PP)												
1 Flat fan nozzle	90°	676.646.xx.40	○	○	-	-	1.6	2.83	3.46	4.00	4.47	6.33	15	15	-	-		
	90°	676.726.xx.40	○	○	-	-	2.1	4.46	5.46	6.30	7.04	9.96	15	15	-	-		
	90°	676.766.xx.40	○	○	-	-	2.3	5.66	6.93	8.00	8.94	12.65	15	15	-	-		
	90°	676.806.xx.40	○	○	-	-	2.6	7.07	8.66	10.00	11.18	15.81	15	15	-	-		
	90°	676.846.xx.40	○	○	-	-	3.0	8.84	10.82	12.50	13.97	19.76	15	15	-	-		
	90°	676.886.xx.40	○	○	-	-	3.4	11.31	13.86	16.00	17.89	25.30	15	15	-	-		
	90°	676.926.xx.40	○	○	-	-	4.1	14.14	17.32	20.00	22.36	31.62	15	15	-	-		
	90°	676.966.xx.40	○	○	-	-	4.2	17.68	21.65	25.00	27.95	39.53	15	15	-	-		
1 Flat fan nozzle	120°	676.647.xx.40	○	○	-	-	1.6	2.83	3.46	4.00	4.47	6.33	15	15	-	-		
	120°	676.727.xx.40	○	○	-	-	2.1	4.46	5.46	6.30	7.04	9.96	15	15	-	-		
	120°	676.767.xx.40	○	○	-	-	2.3	5.66	6.93	8.00	8.94	12.65	15	15	-	-		
	120°	676.807.xx.40	○	○	-	-	2.6	7.07	8.66	10.00	11.18	15.81	15	15	-	-		
	120°	676.847.xx.40	○	○	-	-	3.0	8.84	10.82	12.50	13.97	19.76	15	15	-	-		
	120°	676.887.xx.40	○	○	-	-	3.4	11.31	13.86	16.00	17.89	25.30	15	15	-	-		
	120°	676.927.xx.40	○	○	-	-	4.1	14.14	17.32	20.00	22.36	31.62	15	15	-	-		
Blind nozzle	-	067.630.8F.40.01	○	-	-	-	-	-	-	-	-	-	15	-	-	-		

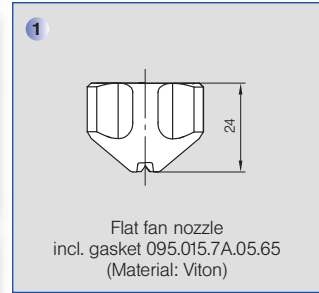

	∠	η	Ordering no.	Material		E Ø [mm]	Flow rate [l/min] at p [bar]					Weight [g]		
				8R	5E		1.0	1.5	2.0	2.5	5.0	PP/316L SS	PVDF	
				Housing: PP Insert: 316L SS	PVDF									
1a Tongue type nozzle	45°	35°	676.803.XX.41	○	-	3.4	7.07	8.66	10.00	11.18	15.81	25	-	
	60°	35°	676.874.XX.41	○	-	4.2	10.61	12.99	15.00	16.77	23.72	25	-	
	60°	35°	676.924.XX.41	○	-	4.7	14.14	17.32	20.00	22.36	31.62	25	-	
	70°	40°	677.005.XX.41	○	○	6.0	22.27	27.28	31.50	35.22	49.81	25	11	

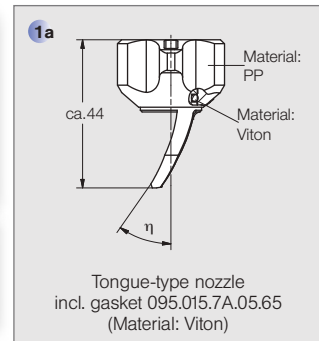

E = narrowest free cross section

Example Type + Material-no. = Ordering no.
for Ordering: 676.646.xx.40 + 8R = 676.646.8R.40



Type	Ordering no.	Material		Spigot-Ø B _R	Recommended bore-Ø	For pipe-Ø	Weight [g]
		53 Polypropylene (PP)	6M PP reinforced				
2a Ball retainer cap	092.080.xx.00.02	○	-				18
2b Ball retainer cap	067.600.xx.40	○	-				18
3 Ball bayonet base	067.630.xx.40	○	-				12
4 Ball seat for eyelet clamp no. 067.631.xx.40.00.0	067.631.xx.40.22	-	○	13.8 mm	14.0–14.3 mm	1 1/4" (40.0–43.0 mm)	9
	067.631.xx.40.02	-	○	16.0 mm	16.5–17.0 mm	1 1/4" (40.0–43.0 mm)	11
	067.631.xx.40.12	-	○	19.8 mm	20.3–20.8 mm	1 1/4" (40.0–43.0 mm)	13
Ball seat for eyelet clamp no. 067.631.xx.50.00.0	067.631.xx.50.22	-	○	13.8 mm	14.0–14.3 mm	1 1/2" (46.0–49.0 mm)	9
	067.631.xx.50.02	-	○	16.0 mm	16.5–17.0 mm	1 1/2" (46.0–49.0 mm)	11
	067.631.xx.50.12	-	○	19.8 mm	20.3–20.8 mm	1 1/2" (46.0–49.0 mm)	13
5a Eyelet clamp	067.631.xx.40.00	○	-	-	-	1 1/4" (40.0–43.0 mm)	31
	067.631.xx.50.00	○	-	-	-	1 1/2" (46.0–49.0 mm)	33
5b Eyelet clamp	090.023.xx.44.10	○	-	13.8 mm	14.0–14.3 mm	1" (32.0–34.5 mm)	48
	090.023.xx.43.10	○	-	16.0 mm	16.5–17.0 mm	1" (32.0–34.5 mm)	48
	090.033.xx.44.10	○	-	13.8 mm	14.0–14.3 mm	1 1/4" (40.0–43.0 mm)	50
	090.033.xx.43.10	○	-	16.0 mm	16.5–17.0 mm	1 1/4" (40.0–43.0 mm)	50
	090.033.xx.40.10	○	-	20.0 mm	20.5–21.0 mm	1 1/4" (40.0–43.0 mm)	50
	090.043.xx.44.10	○	-	13.8 mm	14.0–14.3 mm	1 1/2" (46.0–49.0 mm)	52
	090.043.xx.43.10	○	-	16.0 mm	16.5–17.0 mm	1 1/2" (46.0–49.0 mm)	52
	090.043.xx.40.10	○	-	20.0 mm	20.5–21.0 mm	1 1/2" (46.0–49.0 mm)	52
5c Single clamp	092.080.xx.00	○	-	16.3 mm	16.5–17.0 mm	1" (32.0–34.5 mm)	36
	092.081.xx.00	○	-	16.3 mm	16.5–17.0 mm	1 1/4" (40.0–43.0 mm)	38
	092.082.xx.00	○	-	16.3 mm	16.5–17.0 mm	1 1/2" (46.0–49.0 mm)	40
	092.083.xx.00	○	-	16.3 mm	16.5–17.0 mm	2" (58.0–62.0 mm)	42

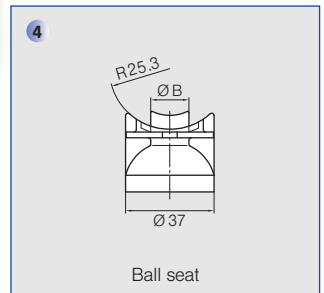
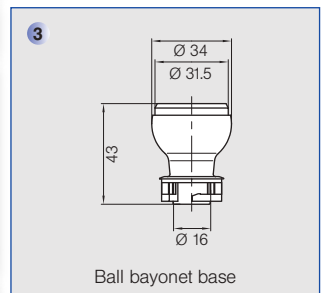
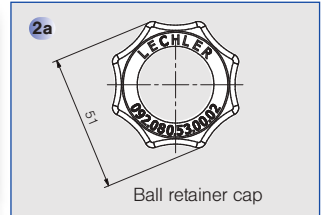

* Other bore-Ø on request
E = narrowest free cross section

Example **Type** + **Material-no.** = **Ordering no.**
for ordering: 092.080.xx.00.02 + 53 = 092.080.53.00.02

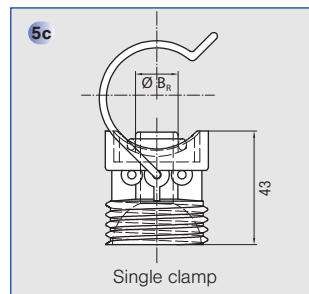
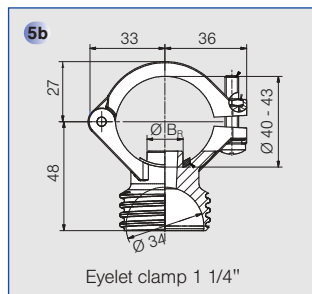
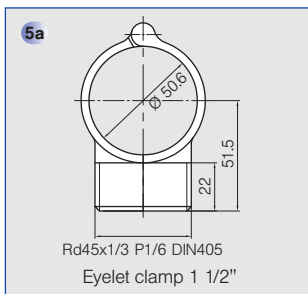



Nozzle systems for surface treatment

Easy-Clip nozzle system

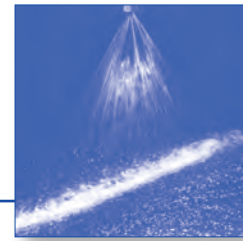

Quick and easy assembly with clamp. No tools required. Allround swivelling by 30°. Easy adjustment and cleaning.

Applications:
Degreasing, phosphating in surface treatment.

Materials:
Clamp: Stainless steel 301 SS
Sealing: EPDM
Cylinder pin, screw and screw unit: 316 SS.
Body, ball retainer cap: PP, reinforced.
Nozzle, ball joint: PP



Sets

Existing of

- Nozzle
- Single clamp for 1 1/4" pipe
- Ball retainer cap

Ordering no.	Nozzle colour	∠	V̇ [l/min]				
			p [bar]				
			0.5	1.0	1.5	2.0	2.5
676. 724. 53. 31	grey	60°	3.15	4.45	5.45	6.30	7.04
676. 764. 53. 31	brown	60°	4.00	5.66	6.93	8.00	8.94
676. 804. 53. 31	lilac	60°	5.00	7.07	8.66	10.00	11.18
676. 844. 53. 31	yellow	60°	6.25	8.84	10.83	12.50	13.98
676. 884. 53. 31	red	60°	8.00	11.31	13.85	16.00	17.89
676. 904. 53. 31	blue	60°	9.10	12.87	15.76	18.20	20.35
676. 924. 53. 31	green	60°	10.00	14.14	17.32	20.00	22.36

Existing of

- Ball joint
- Single clamp for 1 1/4" pipe
- Ball retainer cap

Ordering no.	Ball colour	Nozzle connection	For nozzle series
092. 081. 53. AB	beige	1/8 BSPP	460, 490, 632, 686, 544
092. 081. 53. AD	beige	1/4 BSPP	422, 460, 490, 544, 632, 686
092. 081. 53. AF	beige	3/8 BSPP	422, 460, 490, 632, 686, 688
092. 081. 53. AH	beige	1/2 BSPP	422, 460, 490, 632, 686

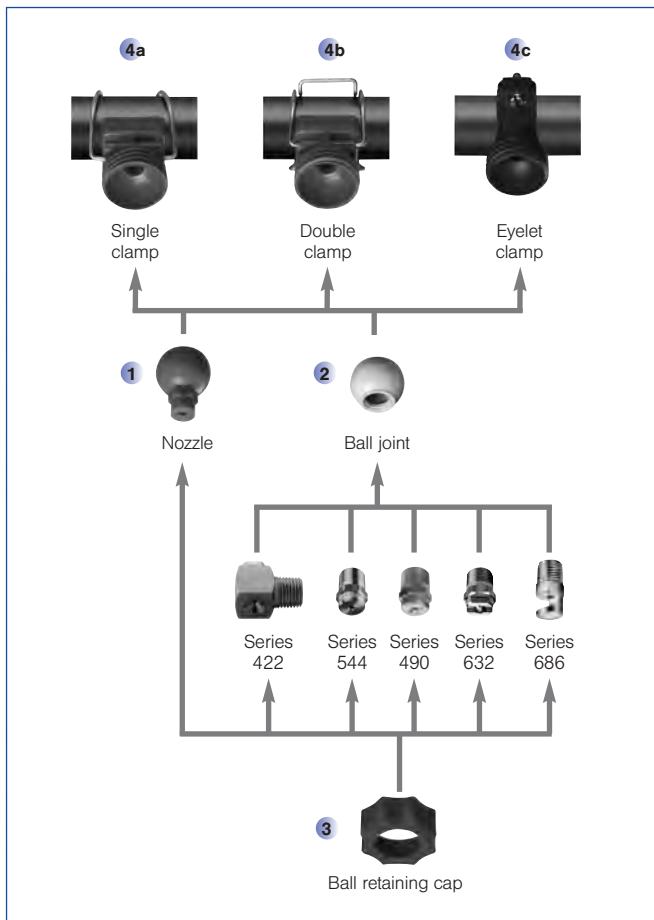

Components

1 Nozzle

Ordering no.	Colour	∠	V̇ [l/min]				
			p [bar]				
			0.5	1.0	1.5	2.0	2.5
676. 724. 53. 30. 01	grey	60°	3.15	4.45	5.45	6.30	7.04
676. 764. 53. 30. 01	brown	60°	4.00	5.66	6.93	8.00	8.94
676. 804. 53. 30. 01	lilac	60°	5.00	7.07	8.66	10.00	11.18
676. 844. 53. 30. 01	yellow	60°	6.25	8.84	10.83	12.50	13.98
676. 884. 53. 30. 01	red	60°	8.00	11.31	13.85	16.00	17.89
676. 904. 53. 30. 01	blue	60°	9.10	12.87	15.67	18.20	20.35
676. 924. 53. 30. 01	green	60°	10.00	14.14	17.32	20.00	22.36
092. 080. 53. 00. 01	grey		Blind nozzle				

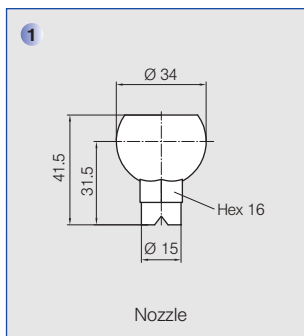



Nozzle systems for surface treatment

Easy-Clip nozzle system



2 Ball joint

Ordering no.	Colour	Nozzle connection	L [mm]	For nozzle series
092. 080. 53. AB. 01	beige	1/8 BSPP	28.4	460, 490, 544, 632, 686
092. 080. 53. AD. 01	beige	1/4 BSPP	32.4	422, 460, 490, 544, 632, 686
092. 080. 53. AF. 01	beige	3/8 BSPP	31.4	422, 460, 490, 632, 686, 688
092. 080. 53. AH. 01	beige	1/2 BSPP	33.0	422, 460, 490, 632, 686

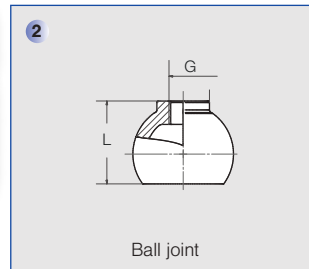

3 Ball retainer cap

Ordering no.
092. 080. 53. 00. 02



4a Single clamp

Ordering no.	Spigot-Ø B _R	Recommended bore-Ø	For Pipe-Ø
092. 080. 53. 00	16.3 mm	16.5-17.0 mm	1" (32.0-34.5 mm)
092. 081. 53. 00	16.3 mm	16.5-17.0 mm	1 1/4" (40.0-43.0 mm)
092. 082. 53. 00	16.3 mm	16.5-17.0 mm	1 1/2" (46.0-49.0 mm)
092. 083. 53. 00	16.3 mm	16.5-17.0 mm	2" (58.0-62.0 mm)

Other spigot-Ø (13.8/19.0 mm) on request.

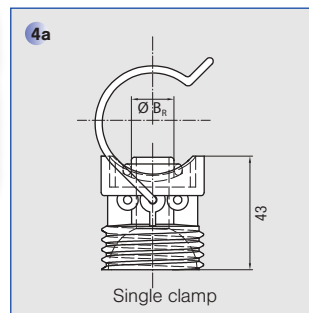

4b Double clamp

Ordering no.	Spigot-Ø B _R	Recommended bore-Ø	For Pipe-Ø
092. 090. 53. 00	16.3 mm	16.5-17.0 mm	1" (32.0-34.5 mm)
092. 091. 53. 00	16.3 mm	16.5-17.0 mm	1 1/4" (40.0-43.0 mm)
092. 092. 53. 00	16.3 mm	16.5-17.0 mm	1 1/2" (46.0-49.0 mm)
092. 093. 53. 00	16.3 mm	16.5-17.0 mm	2" (58.0-62.0 mm)

Other spigot-Ø (13.8/19.0 mm) on request.

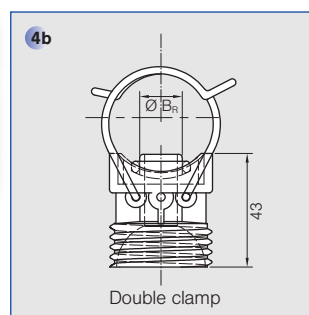

4c Eyelet clamp

Ordering no.	Spigot-Ø B _R	Recommended bore-Ø	For Pipe-Ø
090. 023. 53. 43. 10	16.3 mm	16.5-17.0 mm	1" (32.0-34.5 mm)
090. 033. 53. 43. 10	16.3 mm	16.5-17.0 mm	1 1/4" (40.0-43.0 mm)
090. 043. 53. 43. 10	16.3 mm	16.5-17.0 mm	1 1/2" (46.0-49.0 mm)

Other spigot-Ø (13.8/20.0 mm) on request.

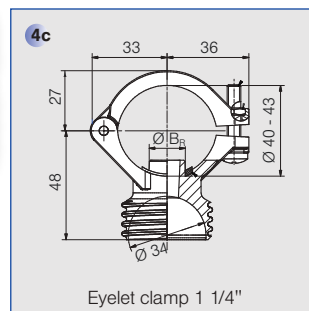



Flat fan nozzles

Series 632/633



Standard design with high-precision spray angle, exact flow rate, and extremely narrow spray depth, achieved through close manufacturing tolerances. This makes the series suitable for even complex cleaning tasks. Parabolic distribution of liquid ensures that spray pipes equipped with these nozzles show an extremely uniform total liquid distribution. Conical, self-sealing thread connection. The entire product range is available at short notice, due to the modular design.

Applications:
Spray cleaning, surface treatment, filter cleaning, belt cleaning, lubricating, coating.

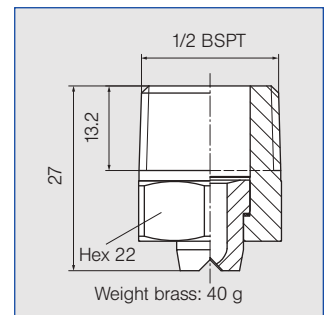
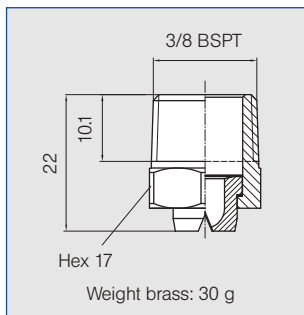
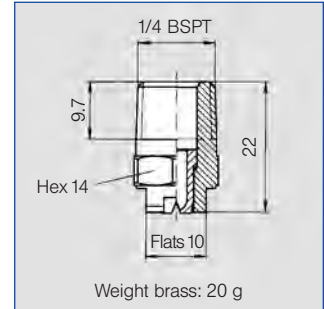
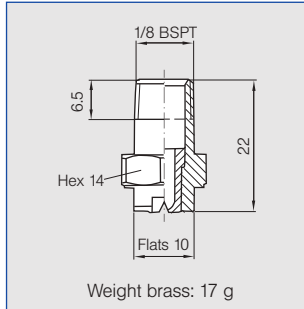
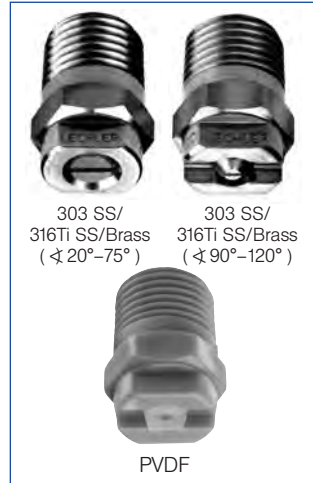

Spray angle	Type	Ordering no.								A Ø [mm]	E Ø [mm]	\dot{V} [l/min]								Spray width B at p = 2 bar	
		Material no.				Code						p [bar]								H = 250 mm	H = 500 mm
		16 ¹⁾	17 ²⁾	30	5E	CA	CC	-	-			0.5	1.0	2.0	3.0	5.0	7.0	10.0			
303 SS/ 304 SS	316Ti SS/ 316L SS	Brass	PVDF	1/8 BSPT	1/4 BSPT	3/8 BSPT	1/2 BSPT														
20°	632. 301	○	○	○	○	CA	CC	-	-	0.70	0.60	0.16*	0.23*	0.32	0.39	0.51	0.60	0.72	65	120	
	632. 361	○	○	○	○	CA	CC	-	-	1.00	0.80	0.31*	0.44*	0.63	0.77	1.00	1.18	1.40	70	130	
	632. 441	○	○	○	○	CA	CC	-	-	1.35	1.10	0.62*	0.88	1.25	1.53	1.98	2.34	2.80	75	145	
	632. 481	○	○	○	○	CA	CC	-	-	1.50	1.20	0.80*	1.13	1.60	1.96	2.53	2.99	3.58	75	150	
30°	632. 302	○	○	○	○	CA	CC	-	-	0.60	0.50	0.16*	0.23*	0.32	0.39	0.51	0.60	0.72	120	235	
	632. 362	○	○	○	○	CA	CC	-	-	1.00	0.70	0.31*	0.44*	0.63	0.77	1.00	1.18	1.40	120	235	
	632. 402	○	○	○	○	CA	CC	-	-	1.20	0.90	0.50*	0.71	1.00	1.23	1.58	1.87	2.24	120	235	
	632. 482	○	○	○	○	CA	CC	-	-	1.50	1.10	0.80*	1.13	1.60	1.96	2.53	2.99	3.58	120	235	
	632. 562	○	○	○	○	CA	CC	-	-	2.00	1.50	1.25	1.77	2.50	3.06	3.95	4.68	5.59	120	235	
	632. 642	○	○	○	-	-	CC	-	-	2.50	1.80	2.00	2.83	4.00	4.90	6.33	7.48	8.94	120	240	
	632. 722	○	○	○	-	-	CC	-	-	3.00	2.40	3.15	4.46	6.30	7.72	9.96	11.79	14.09	125	240	
	632. 762	○	○	○	-	-	CC	-	-	3.50	2.70	4.00	5.66	8.00	9.80	12.65	14.97	17.89	125	240	
	632. 802	○	○	○	-	-	CC	-	-	4.00	3.10	5.00	7.07	10.00	12.25	15.81	18.71	22.36	130	250	

¹⁾ We reserve the right to deliver 303 SS or 304 SS under the material no. 16.
²⁾ We reserve the right to deliver 316Ti SS or 316L SS under the material no. 17.
 A = equivalent bore diameter · E = narrowest free cross section
 * Differing spray pattern
 Subject to technical modifications.

Continued on next page.

Example **Type** + **Material no.** + **Code** = **Ordering no.**
for ordering: 632. 301 + 16 + CA = 632. 301. 16. CA



Flat fan nozzles

Series 632/633



Spray angle	Ordering no.								A Ø [mm]	E Ø [mm]	V̇ [l/min]								Spray width B at p = 2 bar		
	Type	Material no.				Code					p [bar]										
		16 ¹⁾	17 ²⁾	30	5E																
		303 SS/ 304 SS	316Ti SS/ 316L SS	Brass	PVDF	1/8 BSPT	1/4 BSPT	3/8 BSPT			1/2 BSPT	0.5	1.0	2.0	3.0	5.0	7.0	10.0	H = 250 mm	H = 500 mm	
45°	632.303	○	○	○	-	CA	CC	-	-	0.70	0.50	0.16*	0.23*	0.32	0.39	0.51	0.60	0.72	150	270	
	632.363	○	○	○	○	CA	CC	-	-	1.00	0.60	0.31*	0.44*	0.63	0.77	1.00	1.18	1.40	155	280	
	632.403	○	○	○	○	CA	CC	-	-	1.20	0.90	0.50*	0.71	1.00	1.23	1.58	1.87	2.24	175	320	
	632.483	○	○	○	○	CA	CC	-	-	1.50	1.10	0.80*	1.13	1.60	1.96	2.53	2.99	3.58	180	340	
	632.563	○	○	○	○	CA	CC	-	-	2.00	1.40	1.25	1.77	2.50	3.06	3.95	4.68	5.59	185	355	
	632.643	○	○	○	○	CA	CC	-	-	2.50	1.80	2.00	2.83	4.00	4.90	6.33	7.48	8.94	195	370	
	632.673	○	○	○	-	-	CC	CE	-	2.70	2.00	2.83	3.36	4.75	5.82	7.51	8.89	10.62	200	375	
	632.723	○	○	○	-	-	CC	CE	-	3.00	2.40	3.15	4.46	6.30	7.72	9.96	11.79	14.09	200	375	
	632.763	○	○	○	-	-	CC	CE	-	3.50	2.60	4.00	5.66	8.00	9.80	12.65	14.97	17.89	200	380	
	632.803	○	○	○	-	-	CC	CE	CG	4.00	3.00	5.00	7.07	10.00	12.25	15.81	18.71	22.36	205	385	
	632.843	○	○***	○	-	-	CC	-	CG	4.50	3.40	6.25	8.84	12.50	15.31	19.76	23.39	27.95	205	385	
	632.883	○	○	○	-	-	-	-	CG	5.00	3.80	8.00	11.31	16.00	19.60	25.30	29.93	35.78	220	440	
	632.923	○	○	○	-	-	-	-	CG	5.50	4.20	10.00	14.14	20.00	24.50	31.62	37.42	44.72	220	440	
632.963	○	○	○	-	-	-	-	CG	6.00	4.40	12.50	17.68	25.00	30.62	39.53	46.77	55.90	220	440		
60°	632.304	○	○	○	○	CA	CC	-	-	0.70	0.40	0.16*	0.23*	0.32	0.39	0.51	0.60	0.72	215	425	
	632.334	○	○	○	○	CA	CC	-	-	0.90	0.50	0.22*	0.32*	0.45	0.55	0.71	0.84	1.01	220	440	
	632.364	○	○	○	○	CA	CC	-	-	1.00	0.60	0.31*	0.44*	0.63	0.77	1.00	1.18	1.40	230	460	
	632.404	○	○	○	○	CA	CC	-	-	1.20	0.80	0.50*	0.71	1.00	1.23	1.58	1.87	2.24	245	485	
	632.444	○	○	○	○	CA	CC	-	-	1.35	0.90	0.62*	0.88	1.25	1.53	1.98	2.34	2.80	255	495	
	632.484	○	○	○	○	CA	CC	-	-	1.50	1.00	0.80*	1.13	1.60	1.96	2.53	2.99	3.58	260	510	
	632.514	○	○	○	○	CA	CC	-	-	1.65	1.10	0.95*	1.34	1.90	2.33	3.00	3.56	4.25	270	520	
	632.564	○	○	○	○	CA	CC	-	-	2.00	1.30	1.25	1.77	2.50	3.06	3.95	4.68	5.59	280	535	
	632.604	○	○	○	○	CA	CC	-	-	2.20	1.50	1.58	2.23	3.15	3.86	4.98	5.89	7.04	290	550	
	632.644	○	○	○	○**	-	CC	CE	-	2.50	1.60	2.00	2.83	4.00	4.90	6.33	7.48	8.94	295	565	
	632.674	○	○	○	○**	-	CC	CE	-	2.70	1.80	2.38	3.36	4.75	5.82	7.51	8.89	10.62	300	575	
	632.724	○	○	○	○**	-	CC	CE	-	3.00	2.10	3.15	4.46	6.30	7.72	9.96	11.79	14.09	305	590	
	632.764	○	○	○	-	-	CC	CE	-	3.50	2.30	4.00	5.66	8.00	9.80	12.65	14.97	17.89	310	595	
	632.804	○	○***	○	○**	-	CC	-	CG	4.00	2.60	5.00	7.07	10.00	12.25	15.81	18.71	22.36	310	595	
	632.844	○	○***	○	○**	-	CC	-	CG	4.50	3.00	6.25	8.84	12.50	15.31	19.76	23.39	27.95	310	590	
	632.884	○	○***	○	○**	-	CC	-	CG	5.00	3.40	8.00	11.31	16.00	19.60	25.30	29.93	35.78	300	570	
	632.924	○	○	○	-	-	-	-	CG	5.50	4.10	10.00	14.14	20.00	24.50	31.62	37.42	44.72	330	630	
	632.964	○	○	○	-	-	-	-	CG	6.00	4.20	12.50	17.68	25.00	30.62	39.53	46.77	55.90	330	630	
	633.004	○	○	-	-	-	-	-	CG	7.00	4.80	15.75	22.27	31.50	38.57	49.80	58.92	70.43	330	630	
633.044	○	○	○	-	-	-	-	CG	8.00	5.50	20.00	28.28	40.00	48.99	63.25	74.83	89.44	340	640		
633.084	○	○	○	-	-	-	-	CG	9.00	6.80	25.00	35.36	50.00	61.24	79.06	93.54	111.80	340	640		
75°	632.145	○	-	○	-	CA	CC	-	-	0.20	0.12	-	0.04*	0.05	0.06	0.08	0.09	0.11	280	550	
	632.165	○	-	○	-	CA	CC	-	-	0.20	0.14	-	0.05*	0.07	0.08	0.10	0.12	0.15	290	560	
	632.185	○	-	○	-	CA	CC	-	-	0.20	0.16	-	0.06*	0.08	0.10	0.13	0.15	0.18	300	575	
	632.215	○	-	○	-	CA	CC	-	-	0.40	0.20	-	0.08*	0.11	0.14	0.18	0.21	0.25	300	580	
	632.245	○	-	○	-	CA	CC	-	-	0.50	0.30	-	0.12*	0.16	0.20	0.26	0.30	0.36	310	585	
	632.275	○	-	○	-	CA	CC	-	-	0.60	0.30	0.11*	0.16*	0.22	0.27	0.35	0.41	0.49	310	590	

¹⁾ We reserve the right to deliver 303 SS or 304 SS under the material no. 16.

²⁾ We reserve the right to deliver 316Ti SS or 316L SS under the material no. 17.

A = equivalent bore diameter · E = narrowest free cross section

* Differing spray pattern · ** Only available with code CC · *** Only available with code CG

Subject to technical modifications.

Continued on next page.

Example Type + Material no. + Code = Ordering no.
for ordering: 632.303. + 16 + CA = 632.303.16.CA

Conversion formula for the above series: $\dot{V}_2 = \dot{V}_1 \cdot \sqrt{\frac{p_2}{p_1}}$





Flat fan nozzles

Series 632/633



Spray angle	Ordering no.								A Ø [mm]	E Ø [mm]	V̇ [l/min]								Spray width B at p = 2 bar		
	Type	Material no.				Code					p [bar]										
		16 ¹⁾	17 ²⁾	30	5E							0.5	1.0	2.0	3.0	5.0	7.0	10.0			H = 250 mm
		303 SS/ 304 SS	316Ti SS/ 316L SS	Brass	PVDF	1/8 BSPT	1/4 BSPT	3/8 BSPT			1/2 BSPT										
90°	632. 216	○	-	○	-	CA	CC	-	-	0.40	0.20	-	0.08*	0.11	0.14	0.18	0.21	0.25	370	700	
	632. 276	○	-	○	-	CA	CC	-	-	0.60	0.30	0.11*	0.16*	0.22	0.27	0.35	0.41	0.49	375	720	
	632. 306	○	○	○	○	CA	CC	-	-	0.70	0.40	0.16*	0.23*	0.32	0.39	0.51	0.60	0.72	380	740	
	632. 336	○	○	○	○	CA	CC	-	-	0.90	0.50	0.22*	0.32*	0.45	0.55	0.71	0.84	1.01	415	800	
	632. 366	○	○	○	○	CA	CC	-	-	1.00	0.50	0.31*	0.44*	0.63	0.77	1.00	1.18	1.41	420	810	
	632. 406	○	○	○	○	CA	CC	-	-	1.20	0.70	0.50*	0.71	1.00	1.23	1.58	1.87	2.24	430	820	
	632. 446	○	○	○	○	CA	CC	-	-	1.35	0.80	0.62*	0.88	1.25	1.53	1.98	2.34	2.80	435	830	
	632. 486	○	○	○	○	CA	CC	-	-	1.50	0.80	0.80*	1.13	1.60	1.96	2.53	2.99	3.58	440	835	
	632. 516	○	○	○	○	CA	CC	-	-	1.65	0.90	0.95*	1.34	1.90	2.33	3.00	3.56	4.25	440	840	
	632. 566	○	○	○	○	CA	CC	-	-	2.00	1.10	1.25	1.77	2.50	3.06	3.95	4.68	5.59	445	850	
	632. 606	○	○	○	○	CA	CC	-	-	2.20	1.20	1.58	2.23	3.15	3.86	4.98	5.89	7.04	450	860	
	632. 646	○	○	○	○**	-	CC	CE	-	2.50	1.30	2.00	2.83	4.00	4.90	6.33	7.48	8.94	455	865	
	632. 676	○	○	○	○**	-	CC	CE	-	2.70	1.40	2.38	3.36	4.75	5.82	7.51	8.89	10.62	465	875	
	632. 726	○	○	○	○**	-	CC	CE	-	3.00	1.70	3.15	4.46	6.30	7.72	9.96	11.79	14.09	470	885	
	632. 766	○	○	○	○**	-	CC	CE	-	3.50	1.90	4.00	5.66	8.00	9.80	12.65	14.97	17.89	475	890	
	632. 806	○	○***	○	○**	-	CC	-	CG	4.00	2.40	5.00	7.07	10.00	12.25	15.81	18.71	22.36	480	900	
632. 846	○	○***	○	○**	-	CC	-	CG	4.50	2.40	6.25	8.84	12.50	15.31	19.76	23.39	27.95	480	900		
632. 886	○	○***	○	○**	-	CC	-	CG	5.00	3.10	8.00	11.31	16.00	19.60	25.30	29.93	35.78	480	910		
632. 926	○	○	○	-	-	-	-	CG	5.50	3.60	10.00	14.14	20.00	24.50	31.62	37.42	44.72	525	1020		
632. 966	○	○	○	-	-	-	-	CG	6.00	3.90	12.50	17.68	25.00	30.62	39.53	46.77	55.90	525	1020		
120°	632. 187	○	-	○	-	CA	CC	-	-	0.35	0.20	-	0.06*	0.08	0.10	0.13	0.15	0.18	630	1200	
	632. 217	○	-	○	-	CA	CC	-	-	0.40	0.20	-	0.08*	0.11	0.14	0.18	0.21	0.25	640	1210	
	632. 247	○	-	○	-	CA	CC	-	-	0.50	0.20	-	0.12*	0.16	0.20	0.26	0.30	0.36	650	1230	
	632. 277	○	-	○	-	CA	CC	-	-	0.60	0.30	-	0.16*	0.22	0.27	0.35	0.41	0.49	660	1250	
	632. 307	○	○	○	○	CA	CC	-	-	0.70	0.30	0.16*	0.23*	0.32	0.39	0.51	0.60	0.72	660	1250	
	632. 337	○	○	○	○	CA	CC	-	-	0.90	0.40	0.22*	0.32*	0.45	0.55	0.71	0.84	1.01	670	1270	
	632. 367	○	○	○	○	CA	CC	-	-	1.00	0.50	0.31*	0.44*	0.63	0.77	1.00	1.18	1.41	670	1270	
	632. 407	○	○	○	○	CA	CC	-	-	1.20	0.60	0.50*	0.71	1.00	1.23	1.58	1.87	2.24	670	1270	
	632. 447	○	○	○	○	CA	CC	-	-	1.35	0.60	0.62*	0.88	1.25	1.53	1.98	2.34	2.80	675	1270	
	632. 487	○	○	○	○	CA	CC	-	-	1.50	0.60	0.80*	1.13	1.60	1.96	2.53	2.99	3.58	680	1275	
	632. 517	○	○	○	○	CA	CC	-	-	1.65	0.90	0.95*	1.34	1.90	2.33	3.00	3.56	4.25	685	1280	
	632. 567	○	○	○	○	CA	CC	-	-	2.00	0.90	1.25	1.77	2.50	3.06	3.95	4.68	5.59	690	1285	
	632. 607	○	○	○	○	CA	CC	-	-	2.20	1.10	1.58	2.23	3.15	3.86	4.98	5.89	7.04	700	1300	
	632. 647	○	○	○	-	-	CC	CE	-	2.50	1.30	2.00	2.83	4.00	4.90	6.33	7.48	8.94	700	1300	
	632. 677	○	○	○	○**	-	CC	CE	-	2.70	1.40	2.38	3.36	4.75	5.82	7.51	8.89	10.62	720	1330	
	632. 727	○	○	○	○**	-	CC	CE	-	3.00	1.60	3.15	4.46	6.30	7.72	9.96	11.79	14.09	740	1360	
	632. 767	○	○	○	○**	-	CC	CE	-	3.50	1.70	4.00	5.66	8.00	9.80	12.65	14.97	17.89	760	1400	
	632. 807	○	○***	○	-	-	CC	-	CG	4.00	2.00	5.00	7.07	10.00	12.25	15.81	18.71	22.36	790	1450	
	632. 847	○***	○***	○***	○**	-	CC	-	CG	4.50	2.30	6.25	8.84	12.50	15.31	19.76	23.39	27.95	790	1450	
	632. 887	○	○	○	-	-	-	-	CG	5.00	2.60	8.00	11.31	16.00	19.60	25.30	29.93	35.78	800	1460	
632. 927	○	○	○	-	-	-	-	CG	5.50	2.90	10.00	14.14	20.00	24.50	31.62	37.42	44.72	800	1460		

¹⁾ We reserve the right to deliver 303 SS or 304 SS under the material no. 16.

²⁾ We reserve the right to deliver 316Ti SS/316L SS under the material no. 17.

A = equivalent bore diameter · E = narrowest free cross section

* Differing spray pattern · ** Only available with code CC · *** Only available with code CG

Subject to technical modifications.

Example for ordering: Type + Material no. + Code = Ordering no.
632. 216. + 16 + CA = 632. 216. 16. CA



Flat fan nozzles

Series 650/651



Cost-efficient design for standard cleaning tasks and rinsing processes. Series with uniform flat fan and conical, self-sealing thread connection. Suitable for use with spray pipes. Manufactured to order in quantities 250 or greater.

Application: Standard cleaning and rinsing tasks

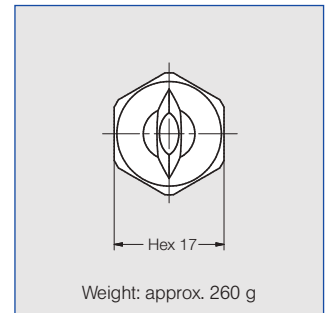
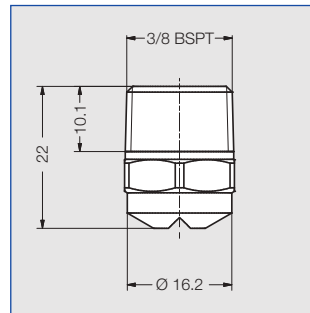
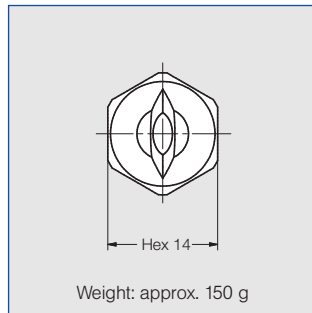
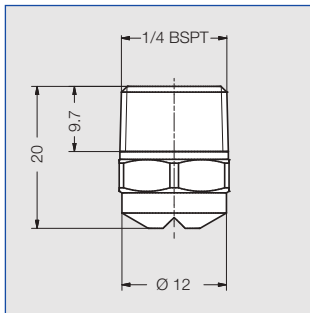
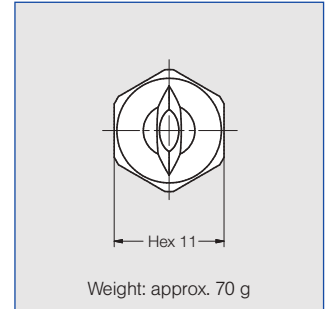
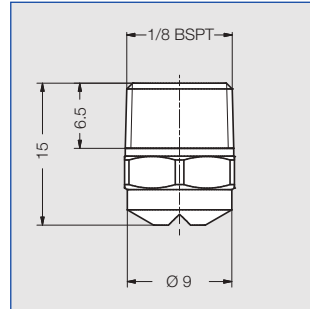

Spray angle	Ordering no.					A Ø [mm]	E Ø [mm]	V̇ [l/min]								Spray width B at p = 2 bar	
	Type	Mat. no. 1C	Code					p [bar]								H = 250 mm	H = 500 mm
			304 SS	1/8 BSPT	1/4 BSPT			3/8 BSPT	0.5	1.0	2.0	3.0	5.0	7.0	10.0		
45°	650. 483	○	CA	CC	-	1.50	1.10	0.80*	1.13	1.60	1.96	2.53	2.99	3.58	180	340	
	650. 563	○	CA	CC	-	2.00	1.40	1.25	1.77	2.50	3.06	3.95	4.68	5.59	185	355	
	650. 603	○	CA	CC	-	2.20	1.60	1.58	2.23	3.15	3.86	4.98	5.89	7.04	195	370	
	650. 643	○	CA	CC	-	2.50	1.80	2.00	2.83	4.00	4.90	6.33	7.48	8.94	195	370	
	650. 673	○	CA	CC	-	2.70	2.00	2.83	3.36	4.75	5.82	7.51	8.89	10.62	200	375	
	650. 723	○	CA	CC	-	3.00	2.40	3.15	4.46	6.30	7.72	9.96	11.79	14.09	200	375	
	650. 763	○	CA	CC	-	3.50	2.60	4.00	5.66	8.00	9.80	12.65	14.97	17.89	200	380	
	650. 803	○	-	CC	-	4.00	3.00	5.00	7.07	10.00	12.25	15.81	18.71	22.36	205	385	
	650. 843	○	-	CC	CE	4.50	3.40	6.25	8.84	12.50	15.31	19.76	23.39	27.95	205	385	
	650. 883	○	-	CC	CE	5.00	3.80	8.00	11.31	16.00	19.60	25.30	29.93	35.78	220	440	
	650. 923	○	-	CC	CE	5.50	4.20	10.00	14.14	20.00	24.50	31.62	37.42	44.72	220	440	
	650. 963	○	-	-	CE	6.00	4.40	12.50	17.68	25.00	30.62	39.53	46.77	55.90	220	440	
	650. 993	○	-	-	CE	6.50	4.80	15.00	21.21	30.00	36.74	47.43	56.12	67.08	220	440	
	651. 003	○	-	-	CE	7.00	5.20	15.75	22.27	31.50	38.57	49.80	58.92	70.43	220	440	
	651. 043	○	-	-	CE	8.00	5.90	20.00	28.28	40.00	48.99	63.25	74.83	89.44	220	440	

A = equivalent bore diameter · E = narrowest free cross section
 * Differing spray pattern
 Subject to technical modifications.

Continued on next page.

Example for ordering: Type 650. 483 + Material no. 1C + Code CA = Ordering no. 650. 483. 1C. CA

Conversion formula for the above series: $\dot{V}_2 = \dot{V}_1 \cdot \sqrt{\frac{p_2}{p_1}}$





Flat fan nozzles

Series 650/651



Spray angle	Ordering no.					A Ø [mm]	E Ø [mm]	V̇ [l/min]							Spray width B at p = 2 bar	
	Type	Mat. no. 1C	Code					p [bar]							H = 250 mm	H = 500 mm
			304 SS	1/8 BSPT	1/4 BSPT			3/8 BSPT	0.5	1.0	2.0	3.0	5.0	7.0		
60°	650.484	○	CA	CC	-	1.50	1.00	0,80*	1,13	1,60	1,96	2,53	2,99	3,58	260	510
	650.564	○	CA	CC	-	2.00	1.30	1,25	1,77	2,50	3,06	3,95	4,68	5,59	280	535
	650.604	○	CA	CC	-	2.20	1.50	1,58	2,23	3,15	3,86	4,98	5,89	7,04	290	550
	650.644	○	CA	CC	-	2.50	1.60	2,00	2,83	4,00	4,90	6,33	7,48	8,94	295	565
	650.674	○	CA	CC	-	2.70	1.80	2,38	3,36	4,75	5,82	7,51	8,89	10,62	300	575
	650.724	○	CA	CC	-	3.00	2.10	3,15	4,46	6,30	7,72	9,96	11,79	14,09	305	590
	650.764	○	CA	CC	-	3.50	2.30	4,00	5,66	8,00	9,80	12,65	14,97	17,89	310	595
	650.804	○	-	CC	-	4.00	2.60	5,00	7,07	10,00	12,25	15,81	18,71	22,36	310	595
	650.844	○	-	CC	CE	4.50	3.00	6,25	8,84	12,50	15,31	19,76	23,39	27,95	310	590
	650.884	○	-	CC	CE	5.00	3.40	8,00	11,31	16,00	19,60	25,30	29,93	35,78	300	570
	650.924	○	-	CC	CE	5.50	4.10	10,00	14,14	20,00	24,50	31,62	37,42	44,72	330	630
	650.964	○	-	-	CE	6,00	4,20	12,50	17,68	25,00	30,62	39,53	46,77	55,90	330	630
	650.994	○	-	-	CE	6,50	4,40	15,00	21,21	30,00	36,74	47,43	56,12	67,08	330	630
651.004	○	-	-	CE	7,00	4,80	15,75	22,27	31,50	38,57	49,80	58,92	70,43	330	630	
651.044	○	-	-	CE	8,00	5,50	20,00	28,28	40,00	48,99	63,25	74,83	89,44	340	640	
90°	650.486	○	CA	CC	-	1.50	0,80	0,80*	1,13	1,60	1,96	2,53	2,99	3,58	440	835
	650.566	○	CA	CC	-	2,00	1,10	1,25	1,77	2,50	3,06	3,95	4,68	5,59	445	850
	650.606	○	CA	CC	-	2,20	1,20	1,58	2,23	3,15	3,86	4,98	5,89	7,04	450	860
	650.646	○	CA	CC	-	2,50	1,30	2,00	2,83	4,00	4,90	6,33	7,48	8,94	455	865
	650.676	○	CA	CC	-	2,70	1,40	2,38	3,36	4,75	5,82	7,51	8,89	10,62	465	875
	650.726	○	CA	CC	-	3,00	1,70	3,15	4,46	6,30	7,72	9,96	11,79	14,09	470	885
	650.766	○	CA	CC	-	3,50	1,90	4,00	5,66	8,00	9,80	12,65	14,97	17,89	475	890
	650.806	○	-	CC	-	4,00	2,40	5,00	7,07	10,00	12,25	15,81	18,71	22,36	480	900
	650.846	○	-	CC	CE	4,50	2,40	6,25	8,84	12,50	15,31	19,76	23,39	27,95	480	900
	650.886	○	-	CC	CE	5,00	3,10	8,00	11,31	16,00	19,60	25,30	29,93	35,78	480	910
	650.926	○	-	CC	CE	5,50	3,60	10,00	14,14	20,00	24,50	31,62	37,42	44,72	525	1020
	650.966	○	-	-	CE	6,00	3,90	12,50	17,68	25,00	30,62	39,53	46,77	55,90	525	1020
	650.996	○	-	-	CE	6,50	3,70	15,00	21,21	30,00	36,74	47,43	56,12	67,08	525	1020
651.006	○	-	-	CE	7,00	4,20	15,75	22,27	31,50	38,57	49,80	58,92	70,43	525	1020	
651.046	○	-	-	CE	8,00	4,90	20,00	28,28	40,00	48,99	63,25	74,83	89,44	525	1020	
120°	650.487	○	CA	CC	-	1.50	0,60	0,80*	1,13	1,60	1,96	2,53	2,99	3,58	680	1275
	650.567	○	CA	CC	-	2,00	0,90	1,25	1,77	2,50	3,06	3,95	4,68	5,59	690	1285
	650.607	○	CA	CC	-	2,20	1,10	1,58	2,23	3,15	3,86	4,98	5,89	7,04	700	1300
	650.647	○	CA	CC	-	2,50	1,30	2,00	2,83	4,00	4,90	6,33	7,48	8,94	700	1300
	650.677	○	CA	CC	-	2,70	1,40	2,38	3,36	4,75	5,82	7,51	8,89	10,62	720	1330
	650.727	○	CA	CC	-	3,00	1,60	3,15	4,46	6,30	7,72	9,96	11,79	14,09	740	1360
	650.767	○	CA	CC	-	3,50	1,70	4,00	5,66	8,00	9,80	12,65	14,97	17,89	760	1400
	650.807	○	-	CC	-	4,00	2,00	5,00	7,07	10,00	12,25	15,81	18,71	22,36	790	1450
	650.847	○	-	CC	CE	4,50	2,30	6,25	8,84	12,50	15,31	19,76	23,39	27,95	790	1450
	650.887	○	-	CC	CE	5,00	2,60	8,00	11,31	16,00	19,60	25,30	29,93	35,78	800	1460
	650.927	○	-	CC	CE	5,00	2,90	10,00	14,14	20,00	24,50	31,62	37,42	44,72	800	1460
	650.967	○	-	-	CE	6,00	3,20	12,50	17,68	25,00	30,62	39,53	46,77	55,90	800	1460
	650.997	○	-	-	CE	6,50	3,40	15,00	21,21	30,00	36,74	47,43	56,12	67,08	800	1460
651.007	○	-	-	CE	7,00	3,70	15,75	22,27	31,50	38,57	49,80	58,92	70,43	800	1460	
651.047	○	-	-	CE	8,00	4,40	20,00	28,28	40,00	48,99	63,25	74,83	89,44	800	1460	

A = equivalent bore diameter • E = narrowest free cross section

* Differing spray pattern

Subject to technical modifications.



Flat fan nozzles for retaining nut

Series 652



Assembly with retaining nut. Easy nozzle changing, simple jet alignment. Uniform, parabolic distribution of liquid. Spray pipes equipped with these nozzles show an extremely uniform total liquid distribution.

Applications:
Spray cleaning, surface treatment, filter cleaning, belt cleaning, lubricating, coating.

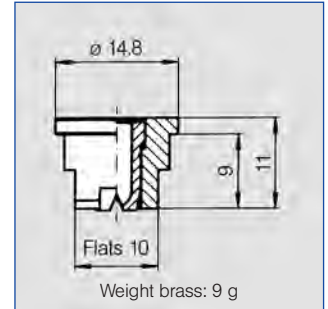

Spray angle	Ordering no.					A Ø [mm]	E Ø [mm]	\dot{V} [l/min]						Spray width B at p = 2 bar	
	Type	Material no.						p [bar]						H =	
		16	17 ¹⁾	30	5E			0.5	1.0	2.0	3.0	5.0	10.0	250 mm	500 mm
	303 SS	316Ti SS/ 316L SS	Brass	PVDF											
20°	652. 301	○	○	○	○	0.70	0.60	0.16*	0.23*	0.32	0.39	0.51	0.72	65	125
	652. 361	○	○	○	○	1.00	0.80	0.31*	0.44*	0.63	0.77	1.00	1.40	65	125
	652. 441	○	○	○	○	1.35	1.10	0.62*	0.88	1.25	1.53	1.98	2.80	65	125
	652. 481	○	○	○	○	1.50	1.20	0.80*	1.13	1.60	1.96	2.53	3.58	65	125
30°	652. 302	○	○	○	○	0.60	0.50	0.16*	0.23*	0.32	0.39	0.51	0.72	115	230
	652. 362	○	○	○	○	1.00	0.70	0.31*	0.44*	0.63	0.77	1.00	1.40	115	230
	652. 402	○	○	○	○	1.20	0.90	0.50*	0.71	1.00	1.23	1.58	2.24	115	230
	652. 482	○	○	○	○	1.50	1.10	0.80*	1.13	1.60	1.96	2.53	3.58	115	230
	652. 562	○	○	○	○	2.00	1.50	1.25	1.77	2.50	3.06	3.95	5.59	115	230
	652. 642	○	○	○	-	2.50	1.80	2.00	2.83	4.00	4.90	6.33	8.94	120	230
	652. 722	○	○	○	-	3.00	2.40	3.15	4.46	6.30	7.72	9.96	14.09	120	235
	652. 762	○	○	○	-	3.50	2.70	4.00	5.66	8.00	9.80	12.65	17.89	120	235
652. 802	○	○	○	-	4.00	3.10	5.00	7.07	10.00	12.25	15.81	22.36	120	240	
45°	652. 303	○	○	○	-	0.70	0.50	0.16*	0.23*	0.32	0.39	0.51	0.72	180	340
	652. 363	○	○	○	○	1.00	0.60	0.31*	0.44*	0.63	0.77	1.00	1.40	185	340
	652. 403	○	○	○	○	1.20	0.90	0.50*	0.71	1.00	1.23	1.58	2.24	185	340
	652. 483	○	○	○	○	1.50	1.10	0.80*	1.13	1.60	1.96	2.53	3.58	185	340
	652. 563	○	○	○	○	2.00	1.40	1.25	1.77	2.50	3.06	3.95	5.59	185	340
	652. 643	○	○	○	○	2.50	1.80	2.00	2.83	4.00	4.90	6.33	8.94	185	345
	652. 723	○	○	○	-	3.00	2.40	3.15	4.46	6.30	7.72	9.96	14.09	190	355
	652. 763	○	○	○	-	3.50	2.60	4.00	5.66	8.00	9.80	12.65	17.89	190	355
652. 803	○	○	○	-	4.00	3.00	5.00	7.07	10.00	12.25	15.81	22.36	195	360	
60°	652. 304	○	○	○	○	0.70	0.40	0.16*	0.23*	0.32	0.39	0.51	0.72	275	525
	652. 334	○	○	○	○	0.90	0.50	0.22*	0.32*	0.45	0.55	0.71	1.01	275	525
	652. 364	○	○	○	○	1.00	0.60	0.31*	0.44*	0.63	0.77	1.00	1.40	275	525
	652. 404	○	○	○	○	1.20	0.80	0.50*	0.71	1.00	1.23	1.58	2.24	275	525
	652. 444	○	○	○	○	1.35	0.90	0.62*	0.88	1.25	1.53	1.98	2.80	280	530
	652. 484	○	○	○	○	1.50	1.00	0.80*	1.13	1.60	1.96	2.53	3.58	280	530
	652. 514	○	○	○	○	1.65	1.10	0.95*	1.34	1.90	2.33	3.00	4.25	280	530
	652. 564	○	○	○	○	2.00	1.30	1.25	1.77	2.50	3.06	3.95	5.59	280	525
	652. 604	○	○	○	○	2.20	1.50	1.58	2.23	3.15	3.86	4.98	7.04	280	520
	652. 644	○	○	○	○	2.50	1.60	2.00	2.83	4.00	4.90	6.33	8.94	275	520
	652. 674	○	○	○	○	2.70	1.80	2.38	3.36	4.75	5.82	7.51	10.62	275	520
	652. 724	○	○	○	○	3.00	2.10	3.15	4.46	6.30	7.72	9.96	14.09	275	520
	652. 764	○	○	○	-	3.50	2.30	4.00	5.66	8.00	9.80	12.65	17.89	270	515
	652. 804	○	○	○	○	4.00	2.60	5.00	7.07	10.00	12.25	15.81	22.36	270	510
	652. 844	○	-	-	○	4.50	3.00	6.25	8.84	12.50	15.31	19.76	27.95	270	510
	652. 884	○	-	○	-	5.00	3.40	8.00	11.31	16.00	19.60	25.30	35.78	270	505

¹⁾ We reserve the right to deliver 316Ti SS or 316L SS under the material no. 17.
A = equivalent bore diameter · E = narrowest free cross section · * Differing spray pattern

Continued on next page

Conversion formula for the above series: $\dot{V}_2 = \dot{V}_1 \cdot \sqrt{\frac{p_2}{p_1}}$





Flat fan nozzles for retaining nut

Series 652



Spray angle	Ordering no.				A Ø [mm]	E Ø [mm]	V̇ [l/min]						Spray width B at p = 2 bar			
	Type	Material no.					p [bar]									
		16	17 ¹⁾	30			5E	0.5	1.0	2.0	[US gal/min] at 40 psi	3.0			5.0	10.0
	303 SS	316T SS/ 316L SS	Brass	PVDF									H = 250 mm	H = 500 mm		
75°	652. 145	○	-	○	-	0.20	0.12	-	0.04*	0.05	0.02	0.06	0.08	0.11	285	550
	652. 165	○	-	○	-	0.20	0.14	-	0.05*	0.07	0.02	0.08	0.10	0.15	285	555
	652. 185	○	-	○	-	0.20	0.16	-	0.06*	0.08	0.02	0.10	0.13	0.18	290	560
	652. 215	○	-	○	-	0.40	0.20	-	0.08*	0.11	0.03	0.14	0.18	0.25	290	560
	652. 245	○	-	○	-	0.50	0.30	-	0.12*	0.16	0.05	0.20	0.26	0.36	290	560
	652. 275	○	-	○	-	0.60	0.30	0.11*	0.16*	0.22	0.07	0.27	0.35	0.49	290	560
90°	652. 216	○	-	○	-	0.40	0.20	0.06*	0.08*	0.11	0.03	0.14	0.18	0.25	380	760
	652. 246	○	-	○	-	0.50	0.30	0.08*	0.12*	0.16	0.05	0.20	0.26	0.36	380	760
	652. 276	○	-	○	-	0.60	0.30	0.11*	0.16*	0.22	0.07	0.27	0.35	0.49	450	795
	652. 306	○	○	○	○	0.70	0.40	0.16*	0.23*	0.32	0.10	0.39	0.51	0.72	450	795
	652. 336	○	○	○	○	0.90	0.50	0.22*	0.32*	0.45	0.14	0.55	0.71	1.01	450	795
	652. 366	○	○	○	○	1.00	0.50	0.31*	0.44*	0.63	0.20	0.77	1.00	1.41	450	795
	652. 406	○	○	○	○	1.20	0.70	0.50*	0.71	1.00	0.31	1.23	1.58	2.24	450	800
	652. 446	○	○	○	○	1.35	0.80	0.62*	0.88	1.25	0.39	1.53	1.98	2.80	450	800
	652. 486	○	○	○	○	1.50	0.80	0.80*	1.13	1.60	0.50	1.96	2.53	3.58	450	800
	652. 516	○	○	○	○	1.65	0.90	0.95*	1.34	1.90	0.59	2.33	3.00	4.25	450	800
	652. 566	○	○	○	○	2.00	1.10	1.25	1.77	2.50	0.78	3.06	3.95	5.59	450	805
	652. 606	○	○	○	○	2.20	1.20	1.58	2.23	3.15	0.98	3.86	4.98	7.04	450	805
	652. 646	○	○	○	○	2.50	1.30	2.00	2.83	4.00	1.24	4.90	6.33	8.94	450	805
	652. 676	○	○	○	○	2.70	1.40	2.38	3.36	4.75	1.47	5.82	7.51	10.62	450	810
	652. 726	○	○	○	○	3.00	1.70	3.15	4.46	6.30	1.95	7.72	9.96	14.09	450	810
	652. 766	○	○	○	-	3.50	1.90	4.00	5.66	8.00	2.48	9.80	12.65	17.89	450	815
	652. 806	○	○	○	○	4.00	2.40	5.00	7.07	10.00	3.10	12.25	15.81	22.36	450	820
	652. 846	-	-	○	○	4.50	2.40	6.25	8.84	12.50	3.88	15.31	19.76	27.95	450	820
652. 886	○	-	○	○	5.00	3.10	8.00	11.31	16.00	4.96	19.60	25.30	35.78	450	835	
120°	652. 187	○	-	○	-	0.35	0.20	-	0.06*	0.08	0.02	0.10	0.13	0.18	640	1220
	652. 217	○	-	○	-	0.40	0.20	-	0.08*	0.11	0.03	0.14	0.18	0.25	650	1230
	652. 247	○	-	○	-	0.50	0.20	-	0.12*	0.16	0.05	0.20	0.26	0.36	655	1245
	652. 277	○	-	○	-	0.60	0.30	-	0.16*	0.22	0.07	0.27	0.35	0.49	655	1250
	652. 307	○	-	○	○	0.70	0.30	0.16*	0.23*	0.32	0.10	0.39	0.51	0.72	660	1260
	652. 337	○	○	○	○	0.90	0.40	0.22*	0.32*	0.45	0.14	0.55	0.71	1.01	660	1260
	652. 367	○	○	○	○	1.00	0.50	0.31*	0.44*	0.63	0.20	0.77	1.00	1.41	660	1265
	652. 407	○	○	○	○	1.20	0.60	0.50*	0.71	1.00	0.31	1.23	1.58	2.24	660	1270
	652. 447	○	○	○	○	1.35	0.60	0.62*	0.88	1.25	0.39	1.53	1.98	2.80	665	1270
	652. 487	○	○	○	○	1.50	0.60	0.80*	1.13	1.60	0.50	1.96	2.53	3.58	665	1270
	652. 517	○	○	○	○	1.65	0.90	0.95*	1.34	1.90	0.59	2.33	3.00	4.25	670	1275
	652. 567	○	○	○	○	2.00	0.90	1.25	1.77	2.50	0.78	3.06	3.95	5.59	670	1280
	652. 607	○	○	○	○	2.20	1.10	1.58	2.23	3.15	0.98	3.86	4.98	7.04	675	1285
	652. 647	○	○	○	-	2.50	1.30	2.00	2.83	4.00	1.24	4.90	6.33	8.94	680	1295
	652. 677	○	○	○	-	2.70	1.40	2.38	3.36	4.75	1.47	5.82	7.51	10.62	685	1300
	652. 727	○	○	○	○	3.00	1.60	3.15	4.46	6.30	1.95	7.72	9.96	14.09	695	1315
	652. 767	○	○	○	-	3.50	1.70	4.00	5.66	8.00	2.48	9.80	12.65	17.89	705	1330
	652. 807	○	-	○	-	4.00	2.00	5.00	7.07	10.00	3.10	12.25	15.81	22.36	705	1330
652. 847	-	-	-	○	4.50	2.30	6.25	8.84	12.50	3.88	15.31	19.76	27.95	800	1460	
652. 887	-	-	-	○	5.00	2.60	8.00	11.31	16.00	4.96	19.60	25.30	35.78	800	1460	

¹⁾ We reserve the right to deliver 316T SS or 316L SS under the material no. 17.
 A = equivalent bore diameter · E = narrowest free cross section
 * Differing spray pattern
 Subject to technical modifications.

Example	Type	+	Material-no.	=	Ordering no.
for ordering:	652. 145	+	16	=	652. 145. 16



Flat fan nozzles with ball joint

Series 676



**Swivelling nozzle for precise adjusting of jet direction.
No gaskets necessary.
Long, unproblematic service life.**

Applications:
Cleaning, cooling, lubricating.

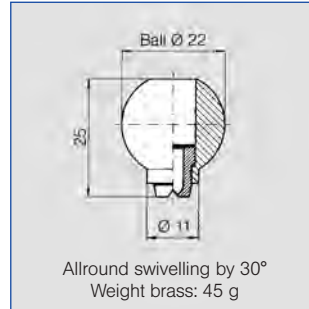
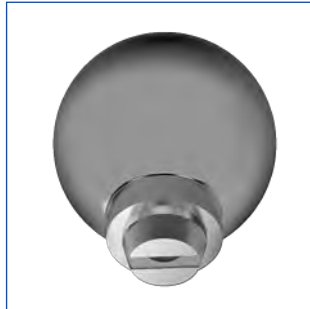

Spray angle	Ordering no.		A Ø [mm]	E Ø [mm]	V̇ [l/min]						Spray width B at p = 2 bar		
	Type	Mat. no.			p [bar] (p _{max} = 30 bar)						H = 250 mm H = 500 mm		
		16			30	0.5	1.0	2.0	3.0	5.0	10.0	B	B
45°	676. 303	○	○	0.70	0.50	0.16*	0.23*	0.32	0.39	0.51	0.72	150	270
	676. 363	○	○	1.00	0.60	0.31*	0.44*	0.63	0.77	1.00	1.40	155	280
	676. 403	○	○	1.20	0.90	0.50*	0.71	1.00	1.23	1.58	2.24	175	320
	676. 483	○	○	1.50	1.10	0.80	1.13	1.60	1.96	2.53	3.58	180	340
	676. 563	○	○	2.00	1.40	1.25	1.77	2.50	3.06	3.95	5.59	185	355
	676. 643	○	○	2.50	1.80	2.00	2.83	4.00	4.90	6.33	8.94	195	370
	676. 723	○	○	3.00	2.40	3.15	4.46	6.30	7.72	9.96	14.09	200	375
	676. 763	○	○	3.50	2.60	4.00	5.66	8.00	9.80	12.65	17.89	200	380
676. 803	○	○	4.00	3.00	5.00	7.07	10.00	12.25	15.81	22.36	205	385	
60°	676. 304	○	○	0.70	0.40	0.16*	0.23*	0.32	0.39	0.51	0.72	215	425
	676. 334	○	○	0.90	0.50	0.22*	0.32*	0.45	0.55	0.71	1.01	220	440
	676. 364	○	○	1.00	0.60	0.31*	0.44*	0.63	0.77	1.00	1.40	230	460
	676. 404	○	○	1.20	0.80	0.50*	0.71	1.00	1.23	1.58	2.24	245	485
	676. 444	○	○	1.35	0.90	0.62*	0.88	1.25	1.53	1.98	2.80	255	495
	676. 484	○	○	1.50	1.00	0.80*	1.13	1.60	1.96	2.53	3.58	260	510
	676. 514	○	○	1.65	1.10	0.95*	1.34	1.90	2.33	3.00	4.25	270	520
	676. 564	○	○	2.00	1.30	1.25	1.77	2.50	3.06	3.95	5.59	280	535
	676. 604	○	○	2.20	1.50	1.58	2.23	3.15	3.86	4.98	7.04	290	550
	676. 644	○	○	2.50	1.60	2.00	2.83	4.00	4.90	6.33	8.94	295	565
	676. 674	○	○	2.70	1.80	2.38	3.36	4.75	5.82	7.51	10.62	300	575
	676. 724	○	○	3.00	2.10	3.15	4.46	6.30	7.72	9.96	14.09	305	590
676. 764	○	○	3.50	2.30	4.00	5.66	8.00	9.80	12.65	17.89	310	595	
90°	676. 216	○	○	0.40	0.20	-	0.08*	0.11	0.14	0.18	0.25	370	700
	676. 276	○	○	0.60	0.30	0.11*	0.16*	0.22	0.27	0.35	0.49	375	720
	676. 306	○	○	0.70	0.40	0.16*	0.23*	0.32	0.39	0.51	0.72	380	740
	676. 336	○	○	0.90	0.50	0.22*	0.32*	0.45	0.55	0.71	1.01	415	800
	676. 366	○	○	1.00	0.50	0.31*	0.44*	0.63	0.77	1.00	1.40	420	810
	676. 406	○	○	1.20	0.70	0.50*	0.71	1.00	1.23	1.58	2.24	430	820
	676. 446	○	○	1.35	0.80	0.62*	0.88	1.25	1.53	1.98	2.80	435	830
	676. 486	○	○	1.50	0.80	0.80*	1.13	1.60	1.96	2.53	3.58	440	835
	676. 516	○	○	1.65	0.90	0.95*	1.34	1.90	2.33	3.00	4.25	440	840
	676. 566	○	○	2.00	1.10	1.25	1.77	2.50	3.06	3.95	5.59	445	850
	676. 606	○	○	2.20	1.20	1.58	2.23	3.15	3.86	4.98	7.04	450	860
	676. 646	○	○	2.50	1.30	2.00	2.83	4.00	4.90	6.33	8.94	455	865
	676. 676	○	○	2.70	1.40	2.38	3.36	4.75	5.82	7.51	10.62	465	875
	676. 726	○	○	3.00	1.70	3.15	4.46	6.30	7.72	9.96	14.09	470	885

A = equivalent bore diameter; E = narrowest free cross section
* Differing spray pattern

Continued on next page.

Conversion formula for the above series: $\dot{V}_2 = \dot{V}_1 \cdot \sqrt{\frac{p_2}{p_1}}$





Flat fan nozzles with ball joint

Series 676







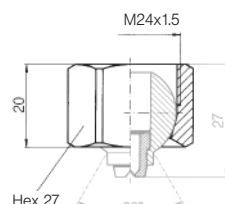

Spray angle	Ordering no.		A ∅ [mm]	E ∅ [mm]	V̇ [l/min]						Spray width B at p = 2 bar			
	Type	Mat. no.			p [bar] (p _{max} = 30 bar)						H = 250 mm		H = 500 mm	
		16			30	0.5	1.0	2.0	3.0	5.0	10.0	B	B	
120°	676. 187	○	○	0.35	0.20	-	0.06*	0.08	0.10	0.13	0.18	630	1200	
	676. 217	○	○	0.40	0.20	-	0.08*	0.11	0.14	0.18	0.25	640	1210	
	676. 247	○	○	0.50	0.20	-	0.12*	0.16	0.20	0.26	0.36	650	1230	
	676. 277	○	○	0.60	0.30	-	0.16*	0.22	0.27	0.35	0.49	660	1250	
	676. 307	○	○	0.70	0.30	0.16*	0.23*	0.32	0.39	0.51	0.72	660	1250	
	676. 337	○	○	0.90	0.40	0.22*	0.32*	0.45	0.55	0.71	1.01	670	1270	
	676. 367	○	○	1.00	0.50	0.31*	0.44*	0.63	0.77	1.00	1.40	670	1270	
	676. 407	○	○	1.20	0.60	0.50*	0.71	1.00	1.23	1.58	2.24	670	1270	
	676. 447	○	○	1.35	0.60	0.62*	0.88	1.25	1.53	1.98	2.80	675	1270	
	676. 487	○	○	1.50	0.60	0.80*	1.13	1.60	1.96	2.53	3.58	680	1275	
	676. 517	○	○	1.65	0.90	0.95*	1.34	1.90	2.33	3.00	4.25	685	1280	
	676. 567	○	○	2.00	0.90	1.25	1.77	2.50	3.06	3.95	5.59	690	1285	
	676. 607	○	○	2.20	1.10	1.58	2.23	3.15	3.86	4.98	7.04	700	1300	
	676. 647	○	○	2.50	1.30	2.00	2.83	4.00	4.90	6.33	8.94	700	1300	
	676. 677	○	○	2.70	1.40	2.38	3.36	4.75	5.82	7.51	10.62	720	1330	
	676. 727	○	○	3.00	1.60	3.15	4.46	6.30	7.72	9.96	14.09	740	1360	
676. 767	○	○	3.50	1.70	4.00	5.66	8.00	9.80	12.65	17.89	760	1400		

A = equivalent bore diameter · E = narrowest free cross section
 * Differing spray pattern

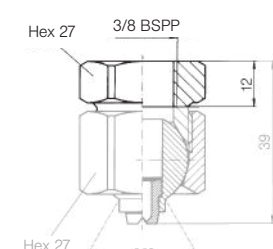
Example	Type	+	Material-no.	=	Ordering no.
for ordering:	676. 187	+	16	=	676. 187. 16

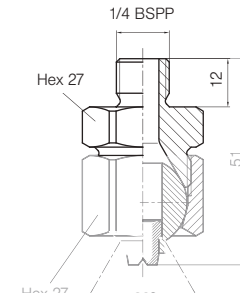
Accessories

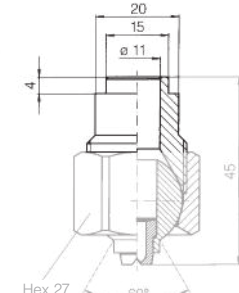
<p>Retaining nut 092. 020. 16. 00. 02 Material: 303 SS 092. 020. 30. 00. 02 Material: Brass</p>  	<p>Socket 092. 020. 16. AF. 03 Material: 303 SS 092. 020. 30. AF. 03 Material: Brass</p>  	<p>Retaining nipple 092. 024. 16. AC. 03 Material: 303 SS 092. 024. 30. AC. 03 Material: Brass</p>  	<p>Welding nipple 092. 020. 17. 00. 04 Material: 316Ti SS</p>  
--	---	---	---



Flat fan nozzles with bayonet quick release cap Series 646



**Quick and easy assembly
with bayonet quick release cap.
Adjusted spray direction.
Uniform liquid distribution.**

Applications:

Belt cleaning, surface
treatment, cleaning, coating
processes.

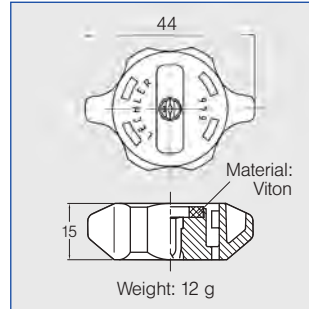

Spray angle	Ordering no.		A Ø [mm]	E Ø [mm]	\dot{V} [l/min]							Spray width B at p = 2 bar	
	Type	Mat. no. 5E			p [bar]							 H = 250 mm H = 500 mm	
					0.5	1.0	2.0	3.0	5.0	7.0	10.0		
45°	646. 363	○	1.00	0.60	0.31*	0.44*	0.63	0.77	1.00	1.18	1.40	185	340
	646. 403	○	1.20	0.90	0.50*	0.71	1.00	1.23	1.58	1.87	2.24	185	340
	646. 483	○	1.50	1.10	0.80*	1.13	1.60	1.96	2.53	2.99	3.58	185	340
	646. 563	○	2.00	1.40	1.20	1.77	2.50	3.06	3.95	4.68	5.59	185	340
	646. 643	○	2.50	1.80	200	2.83	4.00	4.90	6.33	7.48	8.94	185	345
60°	646. 304	○	0.70	0.40	0.16*	0.23*	0.32	0.39	0.51	0.60	0.72	245	490
	646. 334	○	0.90	0.50	0.22*	0.32*	0.45	0.55	0.71	0.84	1.01	250	495
	646. 364	○	1.00	0.60	0.31*	0.44*	0.63	0.77	1.00	1.18	1.40	255	500
	646. 404	○	1.20	0.80	0.50*	0.71	1.00	1.23	1.58	1.87	2.24	260	510
	646. 444	○	1.35	0.90	0.62	0.88	1.25	1.53	1.98	2.34	2.80	260	510
	646. 484	○	1.50	1.00	0.80	1.13	1.60	1.96	2.53	2.99	3.58	270	525
	646. 514	○	1.65	1.10	0.95	1.34	1.90	2.33	3.00	3.56	4.25	260	510
	646. 564	○	2.00	1.30	1.25	1.77	2.50	3.06	3.95	4.68	5.59	260	505
	646. 604	○	2.20	1.50	1.58	2.23	3.15	3.86	4.98	5.89	7.04	265	505
90°	646. 306	○	0.70	0.40	0.16*	0.23*	0.32	0.39	0.51	0.60	0.72	425	840
	646. 336	○	0.90	0.50	0.22*	0.32*	0.45	0.55	0.71	0.84	1.01	425	840
	646. 366	○	1.00	0.50	0.31*	0.44*	0.63	0.77	1.00	1.18	1.41	425	840
	646. 406	○	1.20	0.70	0.50*	0.71	1.00	1.23	1.58	1.87	2.24	425	835
	646. 446	○	1.35	0.80	0.62*	0.88	1.25	1.53	1.98	2.34	2.80	425	835
	646. 486	○	1.50	0.80	0.80*	1.13	1.60	1.96	2.53	2.99	3.58	425	830
	646. 516	○	1.65	0.90	0.95*	1.34	1.90	2.33	3.00	3.56	4.25	425	830
	646. 566	○	2.00	1.10	1.25	1.77	2.50	3.06	3.95	4.68	5.59	425	825
	646. 606	○	2.20	1.20	1.58	2.23	3.15	3.86	4.98	5.89	7.04	425	820
120°	646. 307	○	0.70	0.30	0.16*	0.23*	0.32	0.39	0.51	0.60	0.72	625	1175
	646. 337	○	0.90	0.40	0.22*	0.32*	0.45	0.55	0.71	0.84	1.01	630	1180
	646. 367	○	1.00	0.50	0.31*	0.44*	0.63	0.77	1.00	1.18	1.41	635	1190
	646. 407	○	1.20	0.60	0.50*	0.71	1.00	1.23	1.58	1.87	2.24	640	1195
	646. 447	○	1.35	0.60	0.62*	0.88	1.25	1.53	1.98	2.34	2.80	645	1200
	646. 487	○	1.50	0.60	0.80*	1.13	1.60	1.96	2.53	2.99	3.58	650	1200
	646. 517	○	1.65	0.90	0.95*	1.34	1.90	2.33	3.00	3.56	4.25	650	1205
	646. 567	○	2.00	0.90	1.25	1.77	2.50	3.06	3.95	4.68	5.59	655	1210
	646. 607	○	2.20	1.10	1.58	2.23	3.15	3.86	4.98	5.89	7.04	660	1215

A = equivalent bore diameter · E = narrowest free cross section
* Differing spray pattern
Subject to technical modifications.

Continued on next page.

Example	Type	+	Material no.	=	Ordering no.
for ordering:	646. 363	+	5E	=	646. 363. 5E

Conversion formula for the above series: $\dot{V}_2 = \dot{V}_1 \cdot \sqrt{\frac{p_2}{p_1}}$



Flat fan nozzles for pressing into pipes

Series 612. XXX. 5E. 03



**For pressing into pipes.
Stable spray pattern.
Uniform, parabolic distribu-
tion of liquid.**

Applications:
Cleaning and rinsing, dish
washing.

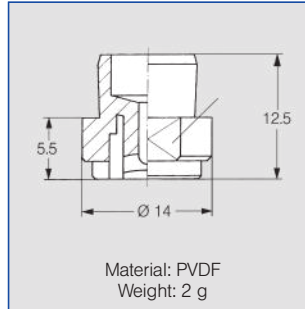

Spray angle	Ordering no.		A Ø [mm]	E Ø [mm]	\dot{V} [l/min]						Spray width B at p = 2 bar	
	Type	Mat. no. 5E. 03			p [bar] P _{max} = 2 bar							
					PVDF	0.3	0.5	0.7	1.0	1.5	2.0	H = 250 mm
90°	612. 366	○	1.0	0.5	0.24	0.31	0.37	0.44	0.55	0.63	505	980
	612. 486	○	1.5	0.6	0.62	0.80	0.95	1.13	1.39	1.60	525	1020
120°	612. 487	○	1.5	0.6	0.62	0.80	0.95	1.13	1.39	1.60	800	1460
	612. 647	○	2.5	1.2	1.55	2.00	2.37	2.83	3.46	4.00	800	1460

A = equivalent bore diameter · E = narrowest free cross section

Further nozzle sizes on request.

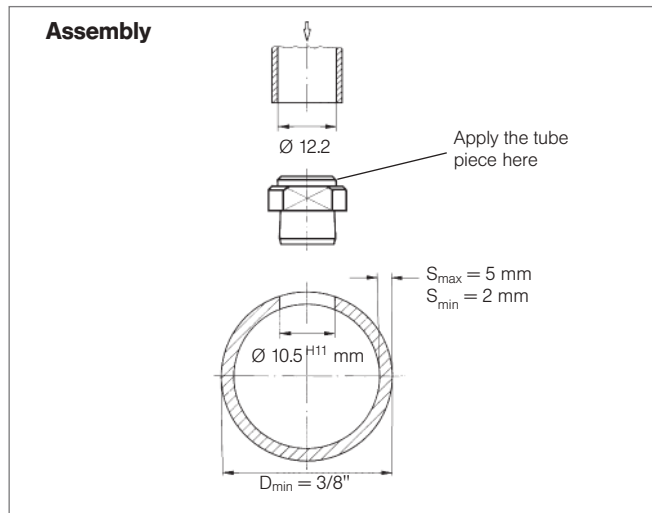

Assembly:
Drill pipe (Ø 10 mm), ream
to Ø 10.5^{H11} mm, adjust, put
tube (Ø 12,2 mm) on nozzle
and drive in with a rubber
mallet. Flow velocity in the
pipe max. 2–3 m/s.

Example	Type	+	Material no.	=	Ordering no.
for ordering:	612. 366	+	5E. 03	=	612. 366. 5E. 03



**Flat fan nozzle for pressing
into pipes with stainless steel
insert**

Flow rate range
0.05–4.00 l/min at 2 bar.

Available on request.



**Full cone nozzle for pressing
into pipes**

Flow rate range
1.6 l/min at 2 bar.

Spray angle 60°.

Available on request.



High pressure flat fan nozzles

Series 602/608/652



Sharp uniform flat fan with an extremely narrow jet depth.

Applications:
High pressure cleaners, steam jet cleaners

Materials:
Nozzle body: 303 SS
Insert: Hardened stainless steel 420F SS

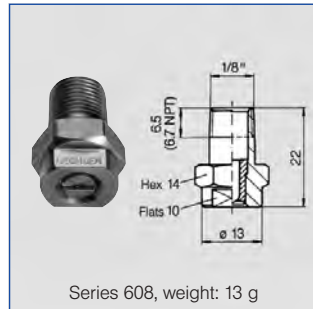

Series 608, weight: 13 g

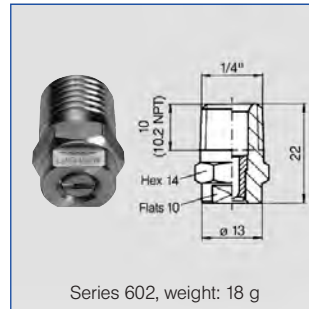

Series 602, weight: 18 g



Series 652, weight: 13 g

US gal/min. at 40 psi	Nozzle code			Flow rate code				A Ø [mm]	V̇ [l/min]						
	Connection			Spray angle					p [bar]						
	1/8	1/4	Nut	↘20°	↘30°	↘45°	↘60°		40	60	80	100	120	150	200
02	608	602	652	361	362	363	364	1.00	2.88	3.53	4.08	4.56	5.00	5.58	6.45
021	608	602	652	371	372	373	374	1.02	3.03	3.71	4.28	4.79	5.25	5.87	6.77
025	608	602	652	381	382	383	384	1.10	3.60	4.42	5.10	5.70	6.24	6.98	8.06
028	608	602	652	391	392	393	394	1.16	4.04	4.94	5.71	6.38	6.99	7.81	9.02
03	608	602	652	401	402	403	404	1.18	4.32	5.29	6.11	6.83	7.48	8.37	9.66
034	608	602	652	411	412	413	414	1.30	4.90	6.00	6.93	7.75	8.49	9.49	10.96
038	608	602	652	441	442	443	-	1.33	5.48	6.72	7.75	8.67	9.50	10.62	12.26
04	608	602	652	451	452	453	454	1.35	5.77	7.06	8.16	9.12	9.99	11.17	12.90
043	608	602	652	461	462	-	-	1.38	6.20	7.59	8.77	9.80	10.74	12.00	13.86
045	608	602	652	471	472	473	474	1.40	6.49	7.95	9.18	10.26	11.24	12.57	14.51
05	608	602	652	481	482	483	484	1.55	7.21	8.83	10.20	11.40	12.49	13.96	16.12
055	608	602	652	501	502	503	504	1.60	7.93	9.71	11.22	12.54	13.74	15.36	17.73
06	608	602	652	521	522	523	524	1.72	8.65	10.60	12.24	13.68	14.99	16.75	19.35
065	608	602	652	531	532	533	534	1.75	9.37	11.48	13.26	14.82	16.23	18.15	20.96
07	608	602	652	541	542	543	544	1.80	10.09	12.36	14.28	15.96	17.48	19.55	22.57
075	608	602	652	551	552	553	554	1.90	10.81	13.25	15.29	17.10	18.73	20.94	24.18
08	608	602	652	571	572	573	574	2.05	11.54	14.13	16.31	18.24	19.98	22.34	25.80
087	608	602	652	581	582	583	584	2.06	12.54	15.36	17.74	19.83	21.72	24.29	28.04
09	608	602	652	591	592	593	594	2.10	12.98	15.89	18.35	20.52	22.48	25.13	29.02
10	608	602	652	601	602	603	604	2.30	14.41	17.65	20.38	22.79	24.97	27.91	32.23
11	-	602	652	621	622	623	624	2.40	15.86	19.42	22.42	25.07	27.46	30.70	35.45
125	-	602	652	641	642	643	644	2.50	18.02	22.07	25.48	28.49	31.21	34.89	40.29
131	-	602	652	651	652	653	654	2.55	18.89	23.13	26.71	29.86	32.71	36.57	42.23
139	-	602	652	661	662	663	664	2.65	20.04	24.54	28.34	31.68	34.70	38.80	44.80
15	-	602	652	671	672	673	674	2.70	21.62	26.48	30.58	34.19	37.45	41.87	48.35
175	-	602	652	701	702	703	704	3.00	25.23	30.90	35.68	39.89	43.70	48.86	56.41
20	-	602	652	-	-	723	724	3.05	28.83	35.31	40.78	45.59	49.94	55.84	64.47
25	-	602	652	-	-	763	764	3.50	36.04	44.14	50.97	56.99	62.43	69.80	80.60
30	-	602	652	-	-	793	-	3.90	43.25	52.97	61.16	68.38	74.91	83.75	96.70

A = equivalent bore diameter

Connection code	Connection	p _{max} * [bar]
A3.00	BSPT	approx. 700
A3.07	NPT	approx. 700
A3.29	Retaining nut	approx. 300

* Only valid for operation at constant pressure.

Example for ordering:	Nozzle code	+	Flow rate code	+	Connection code	=	Ordering no.
	602		361		A3.07		608.361.A3.07
							(Flat fan 20°; 4.52 l/min. at 100 bar; 1/4 NPT)

Conversion formula for the above series: $\dot{V}_2 = \dot{V}_1 * \sqrt{\frac{p_2}{p_1}}$



High pressure flat fan nozzles

Series 6FH



With spray stabilizer. Sharp uniform flat fan with an extremely narrow jet depth.

Applications:

High pressure cleaning.

Materials:

Nozzle body: 303 SS

Insert: Hardened

stainless steel

420F SS

Spray stabilizer: 301 SS

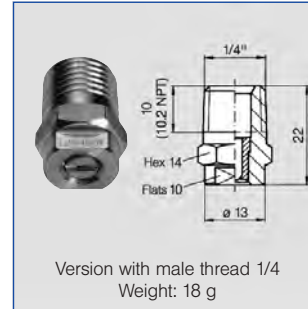
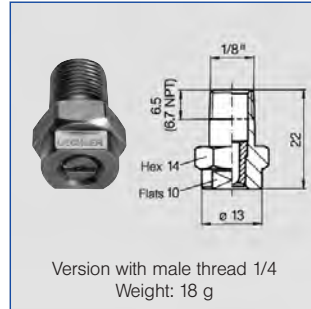

US gal/min. at 40 psi	Nozzle code	Flow rate code				Material no. A3	A Ø [mm]	V̇ [l/min]						
		Spray angle						p [bar]						
		↘20°	↘30°	↘45°	↘60°			40	60	80	100	120	150	200
02	6FH	361	362	363	364	○	1.00	2.88	3.53	4.08	4.56	5.00	5.58	6.45
021	6FH	371	372	373	374	○	1.02	3.03	3.71	4.28	4.79	5.25	5.87	6.77
025	6FH	381	382	383	384	○	1.10	3.60	4.42	5.10	5.70	6.24	6.98	8.06
028	6FH	391	392	393	394	○	1.16	4.04	4.94	5.71	6.38	6.99	7.81	9.02
03	6FH	401	402	403	404	○	1.18	4.32	5.29	6.11	6.83	7.48	8.37	9.66
034	6FH	411	412	413	414	○	1.30	4.90	6.00	6.93	7.75	8.49	9.49	10.96
038	6FH	441	442	443	-	○	1.33	5.48	6.72	7.75	8.67	9.50	10.62	12.26
04	6FH	451	452	453	454	○	1.35	5.77	7.06	8.16	9.12	9.99	11.17	12.90
043	6FH	461	462	-	-	○	1.38	6.20	7.59	8.77	9.80	10.74	12.00	13.86
045	6FH	471	472	473	474	○	1.40	6.49	7.95	9.18	10.26	11.24	12.57	14.51
05	6FH	481	482	483	484	○	1.55	7.21	8.83	10.20	11.40	12.49	13.96	16.12
055	6FH	501	502	503	504	○	1.60	7.93	9.71	11.22	12.54	13.74	15.36	17.73
06	6FH	521	522	523	524	○	1.72	8.65	10.60	12.24	13.68	14.99	16.75	19.35
065	6FH	531	532	533	534	○	1.75	9.37	11.48	13.26	14.82	16.23	18.15	20.96
07	6FH	541	542	543	544	○	1.80	10.09	12.36	14.28	15.96	17.48	19.55	22.57
075	6FH	551	552	553	554	○	1.90	10.81	13.25	15.29	17.10	18.73	20.94	24.18
08	6FH	571	572	573	574	○	2.05	11.54	14.13	16.31	18.24	19.98	22.34	25.80
087	6FH	581	582	583	584	○	2.06	12.54	15.36	17.74	19.83	21.72	24.29	28.04
09	6FH	591	592	593	594	○	2.10	12.98	15.89	18.35	20.52	22.48	25.13	29.02
10	6FH	601	602	603	604	○	2.30	14.41	17.65	20.38	22.79	24.97	27.91	32.23
11	6FH	621*	622*	623*	624*	○	2.40	15.86	19.42	22.42	25.07	27.46	30.70	35.45
125	6FH	641*	642*	643*	644*	○	2.50	18.02	22.07	25.48	28.49	31.21	34.89	40.29
131	6FH	651*	652*	653*	654*	○	2.55	18.89	23.13	26.71	29.86	32.71	36.57	42.23
139	6FH	661*	662*	663*	664*	○	2.65	20.04	24.54	28.34	31.68	34.70	38.80	44.80
15	6FH	671*	672*	673*	674*	○	2.70	21.62	26.48	30.58	34.19	37.45	41.87	48.35
175	6FH	701*	702*	703*	704*	○	3.00	25.23	30.90	35.68	39.89	43.70	48.86	56.41
20	6FH	-	-	723*	724*	○	3.05	28.83	35.31	40.78	45.59	49.94	55.84	64.47
25	6FH	-	-	763*	764*	○	3.50	36.04	44.14	50.97	56.99	62.43	69.80	80.60
30	6FH	-	-	793*	-	○	3.90	43.25	52.97	61.16	68.38	74.91	83.75	96.70

A = equivalent bore diameter · * Only available with connection code CC, BC or 29

Connection code	Connection	p _{max} ** [bar]
CA	1/8 BSPT	approx. 700
BA	1/8 NPT	approx. 700
CC	1/4 BSPT	approx. 700
BC	1/4 NPT	approx. 700
29	Retaining nut	approx. 300

** Only valid for operation at constant pressure.

Example for ordering: Nozzle code 6FH + Flow rate code 361 + Material no. A3 + Connection code CA = Ordering no. 6FH. 361. A3. CA (Flat fan 20°; 4.56 l/min. at 100 bar; 1/8 BSPT)





Tongue-type nozzles for retaining nut

Series 684



Assembly with retaining nut. Wide flat fan with a sharply delimited spray pattern. Not prone to clogging. Easy nozzle changing, simple jet alignment.

Applications:

Foam control in storage tanks and sewage treatment plants. Cleaning and washing process, requiring powerful and concentrated water jets.

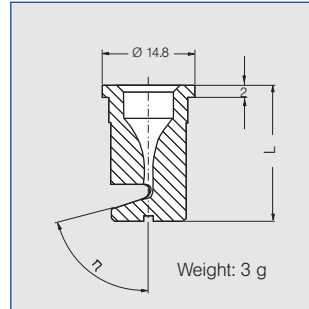

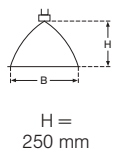
Spray angle	η	Ordering no.		Colour**	B ∅ [mm]	ṽ [l/min]			L [mm]	Spray width B at p = 2 bar  H = 250 mm	
		Type	Mat. no.			p [bar]					
			56			5E	1.0	2.0			5.0
140°	75°	684. 348	○	-	green	0.7	0.35*	0.50	0.79	20	1360
	75°	684. 368	○	○	yellow	0.8	0.45*	0.63	1.00	20	1360
	75°	684. 408	○	-	blue	1.0	0.71	1.00	1.58	20	1370
	75°	684. 448	○	-	red	1.2	0.88	1.25	1.98	20	1370
	75°	684. 488	○	○	brown	1.3	1.13	1.60	2.53	20	1370
	75°	684. 528	○	-	grey	1.5	1.41	2.00	3.16	20	1370
	75°	684. 568	○	○	white	1.7	1.77	2.50	3.95	19	1370
	75°	684. 608	○	-	light blue	1.9	2.23	3.15	4.98	19	1370
	75°	684. 688	○	-	green	2.4	3.54	5.00	7.91	17	1370
	75°	684. 728	○	○	black	2.7	4.45	6.30	9.96	17	1370
	75°	684. 808	○	-	beige	3.4	7.07	10.00	15.81	16	1370

B = bore diameter

* Differing spray pattern · ** Material PVDF generally blue

Example	Type	+	Material no.	=	Ordering no.
for ordering:	684. 348	+	56	=	684. 348. 56

Conversion formula for the above series: $\dot{V}_2 = \dot{V}_1 \cdot \sqrt{\frac{p_2}{p_1}}$



Tongue-type nozzles

Series 686

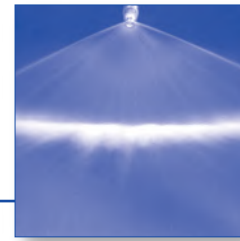

**Wide flat fan with a sharply delimited jet pattern.
Not prone to clogging.**

Applications:
Foam control in storage tanks and sewage treatment plants, cleaning and washing process, requiring powerful and concentrated water jets.

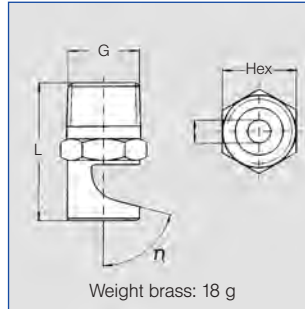

Weight brass: 18 g

Spray angle	η	Ordering no.							B \varnothing [mm]	\dot{V} [l/min]			Dimensions								Spray width B at p = 2 bar  H = 250 mm			
		Type	Material no.			Code G				p [bar]			L [mm]				Hex [mm]							
			16	30	5E	1/8 BSPT	1/4 BSPT	3/8 BSPT		1/2 BSPT	1.0	2.0	5.0	R 1/8	R 1/4	R 3/8	R 1/2	R 1/8	R 1/4	R 3/8		R 1/2		
90°	75°	686.366	-	○	-	CA	-	-	-	0.80	0.45	0.63	1.00	22	-	-	-	-	11	-	-	-	520	
	75°	686.406	○	○	-	CA	-	-	-	1.00	0.71	1.00	1.58	23	-	-	-	-	11	-	-	-	525	
	40°	686.686	○	○	-	-	CC	-	-	2.40	3.54	5.00	7.91	-	29	-	-	-	14	-	-	-	530	
	40°	686.726	-	○	-	CA	-	-	-	2.70	4.45	6.30	9.96	26	-	-	-	-	11	-	-	-	530	
	40°	686.806	○	○	-	-	CC	-	-	3.40	7.07	10.00	15.81	-	34	-	-	-	14	-	-	-	530	
	40°	686.886	○	-	-	-	CC	-	-	4.20	11.31	16.00	25.30	-	36	-	-	-	17	-	-	-	530	
	40°	686.926	○	-	-	-	-	CE	-	4.70	14.14	20.00	31.62	-	-	39	-	-	-	17	-	-	530	
140°	75°	686.368	○	○	-	CA	-	-	-	0.80	0.45	0.63	1.00	23	-	-	-	-	11	-	-	-	1360	
		686.408	○	○	-	CA	-	-	-	1.00	0.71	1.00	1.58	23	-	-	-	-	11	-	-	-	1370	
		686.448	○	○	-	-	CC	-	-	1.20	0.88	1.25	1.98	-	28	-	-	-	14	-	-	-	1370	
		686.488	○	○	-	CA	CC	-	-	1.30	1.13	1.60	2.53	23	28	-	-	-	11	14	-	-	1370	
		686.528	○	○	-	CA	CC	-	-	1.50	1.41	2.00	3.16	23	28	-	-	-	11	14	-	-	1370	
		686.568	○	○	○*	CA	CC	-	-	1.70	1.77	2.50	3.59	23	28	-	-	-	11	14	-	-	1370	
		686.608	○	○	-	CA	CC	-	-	1.90	2.23	3.15	4.98	23	28	-	-	-	11	14	-	-	1370	
		686.648	○	○	-	-	CC	-	-	2.20	2.83	4.00	6.32	-	28	-	-	-	-	14	-	-	-	1370
		686.688	○	○	-	CA	CC	-	-	2.40	3.54	5.00	7.91	23	28	-	-	-	11	14	-	-	1370	
		686.728	○	○	-	CA	CC	-	-	2.70	4.45	6.30	9.96	23	28	-	-	-	11	14	-	-	1370	
		686.768	○	○	-	-	CC	-	-	3.00	5.66	8.00	12.65	-	28	-	-	-	-	14	-	-	-	1370
		686.808	○	○	-	CA	CC	-	-	3.40	7.07	10.00	15.81	23	28	-	-	-	11	14	-	-	1370	
		686.828	○	○	-	-	CC	-	-	3.60	7.92	11.20	17.71	-	28	-	-	-	-	14	-	-	-	1370
		686.848	○	○	-	-	CC	-	-	3.80	8.80	12.50	19.76	-	28	-	-	-	-	14	-	-	-	1370
		686.868	○	○	-	-	CC	-	-	4.00	9.90	14.00	22.14	-	28	-	-	-	-	14	-	-	-	1370
		686.888	○	○	-	-	CC	-	-	4.20	11.31	16.00	25.30	-	28	-	-	-	-	14	-	-	-	1370
		686.908	○	○	-	-	CC	-	-	4.50	12.73	18.00	28.46	-	28	-	-	-	-	14	-	-	-	1370
		686.928	○	-	-	-	-	CE	-	4.70	14.14	20.00	31.62	-	-	32	-	-	-	17	-	-	1370	
		686.968	-	○	-	-	-	-	CG	5.30	17.68	25.00	39.53	-	-	32	40	-	-	17	22	-	1370	
		686.988	○	-	-	-	-	CE	CG	5.60	19.80	28.00	44.27	-	-	32	40	-	-	17	22	-	1370	

B = bore diameter
Can also be used for air or saturated steam.
* Only available with code CA

Example for ordering: Type + Material no. + Code = Ordering no.
686.366 + 30 + CA = 686.366.30.CA



Tongue-type nozzles

Series 688/689



Hard, sharp flat fan, narrowly delimited jet pattern. Not prone to clogging.

Applications:
Cleaning, washing, degreasing and phosphating, preparation techniques.

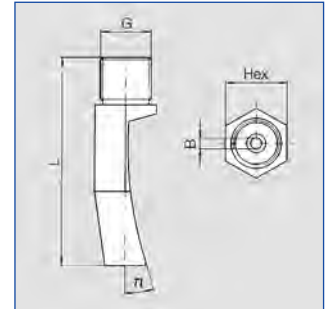

Spray angle	η	Ordering no.						B ∅ [mm]	V̇ [l/min]				Dimensions		Weight	Spray width B at p = 2 bar		
		Type	Mat. no.			Code G			p [bar]				L [mm]	Hex [mm]		H		
			16 303 SS	30 Brass	5E PVDF	1/4 BSPT	3/8 BSPT		3/4 BSPP	0.5	1.0	2.0				5.0	H = 250 [mm]	H = 500 [mm]
45°	36°	688. 603	○	-	-	CC	-	-	1.9	1.57	2.23	3.15	4.98	31	114	50	220	440
	36°	688. 723	○	-	-	-	CE	-	2.7	3.15	4.45	6.30	9.96	44	17	107	220	400
	35°	688. 763	○	-	-	-	CE	-	3.0	4.00	5.66	8.00	12.65	43	19	120	220	440
	30°	688. 843	○	○	-	-	CE	-	3.8	6.25	8.84	12.50	19.76	50	19	140	220	440
	27°	688. 883	○	-	-	-	CE	-	4.3	8.00	11.31	16.00	25.30	67	22	240	220	400
	29°	688. 923	○	○	-	-	CE	-	4.8	10.00	14.14	20.00	31.62	59	22	260	220	440
	29°	688. 943	○	-	-	-	CE	-	4.9	11.20	15.84	22.40	35.41	62	22	300	220	400
	29°	688. 963	○	-	-	-	CE	-	5.4	12.50	17.68	25.00	39.53	74	22	432	220	400
	35°	689. 003	○	-	○	-	-	90	6.0	15.75	22.27	31.50	49.81	80	32/24	306/33	250	490
	21°	689. 043	○	○	-	-	CE	-	6.9	20.00	28.28	40.00	63.25	67	24	630	250	490
	18°	689. 083	○	○	-	-	CE	-	7.6	25.00	35.36	50.00	79.06	74	24	625	250	490
	18°	689. 123	○	○	-	-	CE	-	8.6	31.50	44.55	63.00	99.61	79	24	610	250	490

B = bore diameter

Example **Type** + **Material no.** + **Code** = **Ordering no.**
for ordering: **688. 603** + **16** + **CC** = **688. 603. 16. CC**

Conversion formula for the above series: $\dot{V}_2 = \dot{V}_1 * \sqrt{\frac{p_2}{p_1}}$



Axial-flow full cone nozzles

Series 490/491

Patented



Non-clogging nozzle design with a very stable spray angle, particularly even liquid distribution and large free cross sections.

Applications:

Cleaning and washing processes, surface spraying, container cleaning, foam precipitation, degassing of liquids.



Series 490/491 represents a new generation within the axial-flow full cone nozzles product group. These nozzles were developed using state-of-the-art design and simulation methods (CFD).

Nozzles of series 490/491 replace series 460/461 which are still available on request.

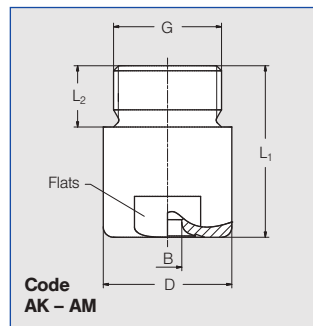
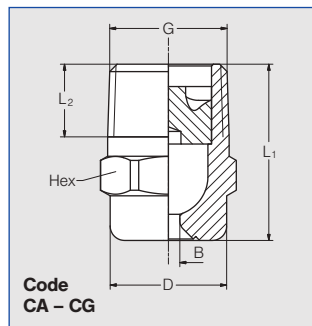

Code	G	Dimensions [mm]			Hex/Flats	Weight brass
		L ₁	L ₂	D		
CA	1/8 BSPT	18.0	6.5	10.0	11	13 g
CC	1/4 BSPT	22.0	10.0	13.0	14	16 g
CE	3/8 BSPT	24.5	10.0	16.0	17	30 g
CE	3/8 BSPT	30.0	10.0	16.0	17	50 g
CG	1/2 BSPT	32.5	13.0	21.0	22	60 g
CG	1/2 BSPT	43.5	13.0	21.0	22	85 g
AK	3/4 BSPP	42.0	15.0	32.0	27	190 g
AM	1 BSPP	56.0	17.0	40.0	36	350 g

Subject to technical modification. In a critical installation situation, please ask for the exact dimensions.

Spray angle	Ordering no.								B Ø [mm]	E Ø [mm]	V̇ [l/min]								Spray diameter D at p = 2 bar					
	Type	Mat. no.		Code							p [bar]								 H = 200 mm H = 500 mm					
		1Y	30	Code		Code					0.5		1.0		2.0		3.0				5.0		7.0	
		316L SS	Brass	1/8 BSPT	1/4 BSPT	3/8 BSPT	1/2 BSPT	3/4 BSPP			1 BSPP	0.5		1.0		2.0		3.0		5.0		7.0		10.0
45°	490. 403	○	○	CA	-	-	-	-	-	1.25	1.25	0.57	0.76	1.00	1.18	1.44	1.65	1.90	160	400				
	490. 523	○	○	CA	-	-	-	-	-	1.70	1.70	1.15	1.52	2.00	2.35	2.89	3.30	3.81	160	400				
	490. 603	○	○	-	CC	CE*	-	-	-	2.00	2.00	1.81	2.39	3.15	3.70	4.54	5.20	6.00	160	400				
	490. 643	○	○	-	CC	CE*	-	-	-	2.45	2.45	2.30	3.03	4.00	4.70	5.77	6.60	7.61	160	400				
	490. 683	-	○	-	-	CE	-	-	-	2.55	2.55	2.87	3.79	5.00	5.88	7.21	8.25	9.52	160	400				
	490. 703	-	○	-	-	CE	-	-	-	2.65	2.65	3.22	4.24	5.60	6.59	8.08	9.24	10.66	160	400				
	490. 723	○	○	-	-	CE	-	-	-	2.85	2.85	3.62	4.77	6.30	7.41	9.09	10.40	11.99	160	400				
	490. 783	-	○	-	-	-	CG	-	-	3.45	3.45	5.17	6.82	9.00	10.58	12.98	14.85	17.12	160	400				
	490. 843	-	○	-	-	-	CG	-	-	3.80	3.80	7.18	9.47	12.50	14.70	18.03	20.63	23.80	160	400				
60°	490. 404	○	○	CA	-	-	-	-	-	1.15	1.15	0.57	0.76	1.00	1.18	1.44	1.65	1.90	220	560				
	490. 444	○	-	CA	-	-	-	-	-	1.25	1.25	0.72	0.95	1.25	1.47	1.80	2.06	2.38	220	560				
	490. 484	○	○	CA	-	-	-	-	-	1.45	1.45	0.92	1.21	1.60	1.88	2.31	2.64	3.05	220	560				
	490. 524	○	○	CA	-	-	-	-	-	1.60	1.60	1.15	1.52	2.00	2.35	2.89	3.30	3.81	220	560				
	490. 564	○	○	CA	-	-	-	-	-	1.80	1.80	1.44	1.89	2.50	2.94	3.61	4.13	4.76	220	560				
	490. 604	○	○	CA	CC	CE	-	-	-	2.05	2.05	1.81	2.39	3.15	3.70	4.54	5.20	6.00	220	560				
	490. 644	○	○	-	CC	CE	-	-	-	2.30	2.30	2.30	3.03	4.00	4.70	5.77	6.60	7.61	220	560				
	490. 684	○	○	-	CC	CE	-	-	-	2.60	2.60	2.87	3.79	5.00	5.88	7.21	8.25	9.52	220	560				
	490. 724	○	○	-	CC	CE	-	-	-	2.95	2.80	3.62	4.77	6.30	7.41	9.09	10.40	11.99	220	560				
	490. 764	○	○	-	-	CE	-	-	-	3.25	3.25	4.59	6.06	8.00	9.41	11.54	13.20	15.22	220	560				
	490. 804	○	○	-	-	CE	-	-	-	3.70	3.70	5.74	7.58	10.00	11.76	14.43	16.51	19.04	220	560				
	490. 844	○	○	-	-	-	CG	-	-	4.05	4.05	7.18	9.47	12.50	14.70	18.03	20.63	23.80	220	560				
	490. 884	○	○	-	-	-	CG	-	-	4.65	4.65	9.19	12.13	16.00	18.82	23.08	26.41	30.46	220	560				
	490. 924	○	○	-	-	-	-	AK	-	5.20	5.20	11.49	15.16	20.00	23.52	28.85	33.01	38.07	220	560				
	490. 964	○	○	-	-	-	-	AK	-	5.80	5.80	14.36	18.95	25.00	29.40	36.07	41.26	47.59	220	560				
	491. 044	○	○	-	-	-	-	-	AM	7.25	7.25	22.97	30.31	40.00	47.04	57.71	66.02	76.15	220	560				
	491. 084	○	○	-	-	-	-	-	AM	8.15	8.15	28.72	37.89	50.00	58.80	72.14	82.53	95.18	220	560				

* Only available in material 30 · B = bore diameter · E = narrowest free cross section

Continued on next page.



Conversion formular for the above series:
(≤ 10 bar)

$$\dot{V}_2 = \dot{V}_1 * \left(\frac{p_2}{p_1} \right)^{0.4}$$



Axial-flow full cone nozzles

Series 490/491

Patented



Spray angle	Ordering no.									B Ø [mm]	E Ø [mm]	V̇ [l/min]							Spray diameter D at p = 2 bar	
	Type	Mat. no.		Code								p [bar]							Diagram	
		1Y	30	1/8 BSPT	1/4 BSPT	3/8 BSPT	1/2 BSPT	3/4 BSPT	1 BSPT			0.5	1.0	2.0	3.0	5.0	7.0	10.0	H = 200 mm	H = 500 mm
	316L SS	Brass	CA																	
90°	490.406	○	○	CA	-	-	-	-	-	1.20	1.20	0.57	0.76	1.00	1.18	1.44	1.65	1.90	380	860
	490.446	-	○	CA	-	-	-	-	-	1.30	1.30	0.72	0.95	1.25	1.47	1.80	2.06	2.38	380	860
	490.486	○	○	CA	-	-	-	-	-	1.45	1.45	0.92	1.21	1.60	1.88	2.31	2.64	3.05	380	860
	490.526	○	○	CA	-	-	-	-	-	1.70	1.55	1.15	1.52	2.00	2.35	2.89	3.30	3.81	380	860
	490.566	○	○	CA	-	-	-	-	-	1.90	1.90	1.44	1.89	2.50	2.94	3.61	4.13	4.76	380	860
	490.606	○	○	CA	-	CE	-	-	-	2.10	2.05	1.81	2.39	3.15	3.70	4.54	5.20	6.00	380	860
	490.646	○	○	-	CC	CE	-	-	-	2.40	2.40	2.30	3.03	4.00	4.70	5.77	6.60	7.61	390	960
	490.686	○	○	-	CC	CE	-	-	-	2.70	2.70	2.87	3.79	5.00	5.88	7.21	8.25	9.52	390	960
	490.726	○	○	-	CC	CE	-	-	-	3.20	2.80	3.62	4.77	6.30	7.41	9.09	10.40	11.99	390	960
	490.746	○	○	-	-	CE	-	-	-	3.15	3.15	4.08	5.38	7.10	8.35	10.24	11.72	13.52	390	960
	490.766	○	○	-	-	CE	-	-	-	3.40	3.40	4.59	6.06	8.00	9.41	11.54	13.20	15.22	390	960
	490.806	○	○	-	-	CE	-	-	-	3.90	3.90	5.74	7.58	10.00	11.76	14.43	16.51	19.04	390	960
	490.846	○	○	-	-	CE	-	-	-	4.65	4.00	7.18	9.47	12.50	14.70	18.03	20.63	23.80	390	960
	490.886	○	○	-	-	-	CG	-	-	5.45	4.50	9.19	12.13	16.00	18.82	23.08	26.41	30.46	390	960
	490.926	○	○	-	-	-	CG	-	-	5.90	4.50	11.49	15.16	20.00	23.52	28.85	33.01	38.07	390	960
	490.966	○	○	-	-	-	CG	AK	-	6.55	4.85	14.36	18.95	25.00	29.40	36.07	41.26	47.59	390	960
	491.006	○	○	-	-	-	-	AK	-	7.55	5.50	18.09	23.87	31.50	37.05	45.45	51.99	59.97	390	960
	491.046	○	○	-	-	-	-	AK	-	8.60	6.60	22.97	30.31	40.00	47.04	57.71	66.02	76.15	390	960
	491.086	○	○	-	-	-	-	-	AM	9.45	7.25	28.72	37.89	50.00	58.80	72.14	82.53	95.18	390	960
	491.126	○	○	-	-	-	-	-	AM	10.40	8.00	36.18	47.75	63.00	74.09	90.89	103.98	119.93	390	960
491.146	○	-	-	-	-	-	-	AM	11.00	7.50	40.78	53.81	71.00	83.50	102.43	117.19	135.16	390	960	
120°	490.368	○	○	CA	-	-	-	-	-	0.85	0.65	0.36	0.48	0.63	0.74	0.91	1.04	1.20	680	1220
	490.408	○	○	CA	-	-	-	-	-	1.20	1.20	0.57	0.76	1.00	1.18	1.44	1.65	1.90	680	1220
	490.448	○	○	CA	-	-	-	-	-	1.30	1.30	0.72	0.95	1.25	1.47	1.80	2.06	2.38	680	1220
	490.488	○	○	CA	-	-	-	-	-	1.45	1.45	0.92	1.21	1.60	1.88	2.31	2.64	3.05	680	1220
	490.528	○	○	CA	-	-	-	-	-	1.70	1.70	1.15	1.52	2.00	2.35	2.89	3.30	3.81	680	1220
	490.568	○	○	CA	-	-	-	-	-	1.90	1.90	1.44	1.89	2.50	2.94	3.61	4.13	4.76	680	1220
	490.608	○	○	CA	-	-	-	-	-	2.10	2.05	1.81	2.39	3.15	3.70	4.54	5.20	6.00	680	1220
	490.648	○	○	-	CC	CE	-	-	-	2.40	2.40	2.30	3.03	4.00	4.70	5.77	6.60	7.61	680	1330
	490.688	○	○	-	CC	CE	-	-	-	2.75	2.75	2.87	3.79	5.00	5.88	7.21	8.25	9.52	680	1330
	490.728	○	○	-	CC	CE	-	-	-	3.20	2.80	3.62	4.77	6.30	7.41	9.09	10.40	11.99	680	1330
	490.748	○	○	-	-	CE	-	-	-	3.20	3.20	4.08	5.38	7.10	8.35	10.24	11.72	13.52	680	1330
	490.768	○	○	-	-	CE	-	-	-	3.45	3.45	4.59	6.44	8.00	9.41	11.54	13.20	15.22	680	1330
	490.808	○	○	-	-	CE	-	-	-	3.90	3.90	5.74	7.58	10.00	11.76	14.43	16.51	19.04	680	1330
	490.848	○	○	-	-	CE	-	-	-	4.70	4.00	7.18	9.47	12.50	14.70	18.03	20.63	23.80	680	1330
	490.888	○	○	-	-	-	CG	-	-	5.10	4.50	9.19	12.13	16.00	18.82	23.08	26.41	30.46	680	1330
	490.928	○	○	-	-	-	CG	-	-	5.80	4.75	11.49	15.16	20.00	23.52	28.85	33.01	38.07	680	1330
	490.968	○	○	-	-	-	CG	AK	-	6.65	4.85	14.36	18.95	25.00	29.40	36.07	41.26	47.59	680	1330
	491.048	○	○	-	-	-	-	AK	-	9.20	5.85	22.97	30.31	40.00	47.04	57.71	66.02	76.15	680	1330
	491.128	○	○	-	-	-	-	-	AM	10.80	7.75	36.18	47.75	63.00	74.09	90.89	103.98	119.93	680	1330
	491.148	○	-	-	-	-	-	-	AM	11.40	7.65	40.78	53.81	71.00	83.50	102.43	117.19	135.16	680	1330

B = bore diameter · E = narrowest tree cross section

Example for ordering: Type + Material no. + Code = Ordering no.
490.406 + 1Y + CA = 490.406.1Y.CA

Other nozzle materials (special alloys, plastics) are available on request.

Conversion formular for the above series: (≤ 10 bar)

$$\dot{V}_2 = \dot{V}_1 * \left(\frac{p_2}{p_1}\right)^{0.4}$$





Axial-flow full cone nozzles

Series 460/461



**Very uniform spray pattern.
Large free cross-sections,
due to optimized x-style swirl
insert.**

Applications:

Cleaning and washing process,
cooling of gaseous fluids and
solids, surface spraying, spraying
onto mats in air washers,
improving of chemical reactions.

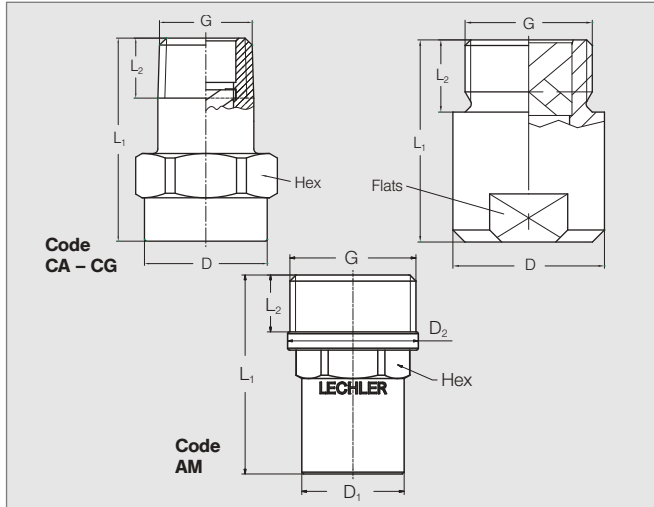

Subject to technical modifications. Please enquire about the exact dimensions if the installation situation is critical!

Code	G	Dimensions [mm]					Hex / Flats
		L ₁	L ₂	D ₁	D ₂		
CA	1/8 BSPT	22.0	6.5	13.0	-	14	
CC	1/4 BSPT	22.0	9.7	13.0	-	14	
CE	3/8 BSPT	30.0	10.0	17.0	-	17	
CG	1/2 BSPT	43.5	13.2	22.0	-	22	
AK	3/4 BSPP	42.0	15.0	31.5	-	27	
AM	1 BSPP	52.5	15.0	27.0	34.5	27	

Spray angle	Type	Mat. no. 5E	Ordering no. Code							B Ø [mm]	E Ø [mm]	V̇ [l/min]							Spray diameter D at p = 2 bar	
			PVDf	1/8 BSPT	1/4 BSPT	3/8 BSPT	1/2 BSPT	3/4 BSPP	1 BSPP			p [bar]							H = 200 mm	H = 500 mm
												0.5	1.0	2.0	3.0	5.0	7.0	10.0		
60°	460.524	○	CA	-	-	-	-	-	1.60	1.60	1.00	1.41	2.00	2.45	2.83	3.16	4.47	220	560	
	460.644	○	-	CC	-	-	-	-	2.40	1.90	2.30	3.03	4.00	4.70	5.77	6.60	7.61	220	560	
	460.724	○	-	CC	-	-	-	-	2.80	2.10	3.15	4.45	6.30	7.72	8.91	9.96	14.09	220	560	
	460.964	○	-	-	-	-	-	AK	-	5.80	4.90	14.36	18.95	25.00	29.40	36.07	41.26	47.59	220	560
90°	460.326	○	CA	-	-	-	-	-	0.80	0.55	0.23	0.30	0.40	0.47	0.58	0.66	0.76	380	860	
	460.406	○	CA	-	-	-	-	-	1.20	0.85	0.57	0.76	1.00	1.18	1.44	1.65	1.90	380	860	
	460.486	○	CA	-	-	-	-	-	1.45	1.20	0.92	1.21	1.60	1.88	2.31	2.64	3.05	380	860	
	460.526	○	CA	-	-	-	-	-	1.65	1.30	1.15	1.52	2.00	2.35	2.89	3.30	3.81	380	860	
	460.606	○	CA	-	CE	-	-	-	2.05	1.45	1.81	2.39	3.15	3.70	4.54	5.20	6.00	380	860	
	460.646	○	-	CC	-	-	-	-	2.30	1.80	2.30	3.03	4.00	4.70	5.77	6.60	7.61	390	960	
	460.726	○	-	-	CE	-	-	-	2.95	2.00	3.62	4.77	6.30	7.41	9.09	10.40	11.99	390	960	
	460.746	○	-	-	CE	-	-	-	3.30	1.90	4.08	5.38	7.10	8.35	10.24	11.72	13.52	390	960	
	460.766	○	-	-	CE	-	-	-	3.30	2.40	4.59	6.06	8.00	9.41	11.54	13.20	15.22	390	960	
	460.806	○	-	-	CE	-	-	-	3.70	2.70	5.74	7.58	10.00	11.76	14.43	16.51	19.04	390	960	
	460.846	○	-	-	CE	-	-	-	4.05	3.20	7.18	9.47	12.50	14.70	18.03	20.63	23.80	390	960	
	460.886	○	-	-	CE	CG	-	-	4.70	3.10	9.19	12.13	16.00	18.82	23.08	26.41	30.46	390	960	
	460.926	○	-	-	-	CG	-	-	5.10	2.80	10.00	14.14	20.00	24.49	28.28	31.62	44.72	390	960	
	460.956	○	-	-	-	CG	-	-	5.10	2.80	10.00	14.14	20.00	24.49	28.28	31.62	44.72	390	960	
	460.966	○	-	-	-	CG	-	-	5.80	3.80	14.36	18.95	25.00	29.40	36.07	41.26	47.59	390	960	
	461.006	○	-	-	-	CG	-	-	6.40	3.80	18.09	23.87	31.50	37.05	45.45	51.99	59.97	390	960	
	461.046	○	-	-	-	CK*	-	-	7.20	5.30	22.97	30.31	40.00	47.04	57.71	66.02	76.15	390	960	
	461.068	○	-	-	-	-	AM	-	8.40	5.00	25.00	35.36	50.00	61.24	70.71	79.06	111.80	390	860	

B = bore diameter - E = narrowest free cross section

* Connection 3/4 BSPT

Continued on next page.

Example for ordering:	Type	+ Material no.	+ Code	= Ordering no.
	460.644	+ 5E	+ CC	= 460.644.5E.CC



Conversion formular for the above series:
(≤ 10 bar)

$$\dot{V}_2 = \dot{V}_1 * \left(\frac{p_2}{p_1} \right)^{0.4}$$



Axial-flow full cone nozzles

Series 460/461



Spray angle A	Ordering no.								B ∅ [mm]	E ∅ [mm]	V̇ [l/min]								Spray diameter D at p = 2 bar	
	Type	Mat. no. 5E	Code								p [bar]									
			PVDf	1/8 BSPT	1/4 BSPT	3/8 BSPT	1/2 BSPT	3/4 BSPP			1 BSPP									
												0.5	1.0	2.0	3.0	5.0	7.0	10.0	H = 200 mm	H = 500 mm
120°	460. 368	○	CA	-	-	-	-	-	0.95	0.45	0.32	0.45	0.63	0.77	0.89	1.00	1.41	680	1220	
	460. 408	○	CA	-	-	-	-	-	1.20	0.85	0.57	0.76	1.00	1.18	1.44	1.65	1.90	680	1220	
	460. 488	○	CA	-	-	-	-	-	1.50	1.00	0.92	1.21	1.60	1.88	2.31	2.64	3.05	680	1220	
	460. 528	○	CA	-	-	-	-	-	1.65	1.20	1.15	1.52	2.00	2.35	2.89	3.30	3.81	680	1220	
	460. 608	○	CA	-	-	-	-	-	2.10	1.40	1.81	2.39	3.15	3.70	4.54	5.20	6.00	680	1220	
	460. 648	○	-	CC	-	-	-	-	2.45	1.60	2.30	3.03	4.00	4.70	5.77	6.60	7.61	680	1330	
	460. 728	○	-	-	CE	-	-	-	3.10	1.90	3.62	4.77	6.30	7.41	9.09	10.40	11.99	680	1330	
	460. 748	○	-	-	CE	-	-	-	3.30	1.90	4.08	5.38	7.10	8.35	10.24	11.72	13.52	680	1330	
	460. 768	○	-	-	CE	-	-	-	3.50	1.90	4.59	6.44	8.00	9.41	11.54	13.20	15.22	680	1330	
	460. 808	○	-	-	CE	-	-	-	3.80	2.40	5.74	7.58	10.00	11.76	14.43	16.51	19.04	680	1330	
	460. 848	○	-	-	CE	-	-	-	4.20	2.70	7.18	9.47	12.50	14.70	18.03	20.63	23.80	680	1330	
	460. 888	○	-	-	-	CG	-	-	4.60	3.10	9.19	12.13	16.00	18.82	23.08	26.41	30.46	680	1330	
	460. 968	○	-	-	-	CG	-	-	5.90	4.10	14.36	18.95	25.00	29.40	36.07	41.26	47.59	680	1330	
461. 048	⊗	-	-	-	-	CK*	-	7.60	4.90	22.97	30.31	40.00	47.04	57.71	66.02	76.15	680	1330		

B = bore diameter · E = narrowest free cross section

⊗ Material PP (material no. 53)

* Connection 3/4 BSPT

Example Type + Material no. + Code = Ordering no.
for ordering: 460. 408 + 5E + CA = 460. 408. 5E. CA

Conversion formular for the above series:
 (≤ 10 bar)

$$\dot{V}_2 = \dot{V}_1 * \left(\frac{p_2}{p_1} \right)^{0.4}$$



High-pressure solid stream nozzles

Series 546/548/550

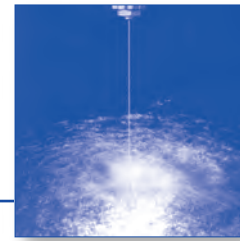

Punctiform, extremely tight, non-dispersing solid stream. Highest impact.

Applications:
High-pressure cleaning, cutting and separating.

Materials:
Nozzle body: 303 SS
Insert: Hardened stainless steel
420F SS

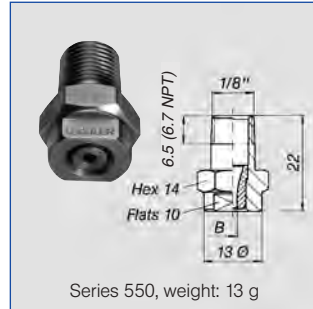

Series 550, weight: 13 g

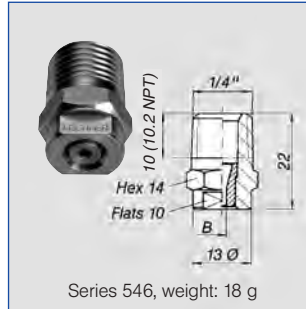

Series 546, weight: 18 g

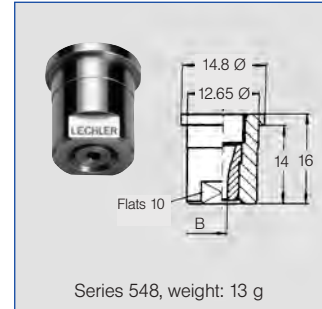

Series 548, weight: 13 g

US gal/min. at 40 psi	Nozzle code			Flow rate code	B Ø [mm]	\dot{V} [l/min]							
	Connection		Retaining nut			p [bar]							
	1/8	1/4				40	60	80	100	120	150	200	300
01	550	546	548	300	0.60	1.44	1.77	2.04	2.28	2.50	2.79	3.22	3.95
02	550	546	548	360	0.84	2.88	3.53	4.08	4.56	5.00	5.58	6.45	7.90
025	550	546	548	380	0.94	3.60	4.42	5.10	5.70	6.24	6.98	8.06	9.87
027	550	546	548	390	0.99	3.89	4.76	5.50	6.15	6.74	7.53	8.70	10.65
03	550	546	548	400	1.03	4.33	5.30	6.12	6.84	7.49	8.38	9.67	11.85
034	550	546	548	410	1.07	4.90	6.00	6.93	7.75	8.49	9.49	10.96	13.42
035	550	546	548	420	1.11	5.05	6.18	7.14	7.98	8.74	9.77	11.29	13.82
038	550	546	548	440	1.15	5.48	6.71	7.75	8.66	9.49	10.61	12.25	15.00
04	550	546	548	450	1.19	5.77	7.06	8.16	9.12	9.99	11.17	12.90	15.80
045	550	546	548	470	1.26	6.49	7.95	9.18	10.26	11.24	12.57	14.51	17.77
05	550	546	548	480	1.33	7.21	8.83	10.20	11.40	12.49	13.96	16.12	19.75
055	550	546	548	500	1.39	7.93	9.71	11.22	12.54	13.74	15.36	17.73	21.72
06	550	546	548	520	1.46	8.65	10.60	12.24	13.68	14.99	16.75	19.35	23.69
065	550	546	548	530	1.51	9.37	11.48	13.26	14.82	16.23	18.15	20.96	25.67
070	550	546	548	540	1.58	10.09	12.36	14.28	15.96	17.48	19.55	22.57	27.64
074	550	546	548	550	1.62	10.67	13.07	15.09	16.87	18.48	20.66	23.86	29.22
08	550	546	548	570	1.69	11.54	14.13	16.31	18.24	19.98	22.34	25.80	31.59
087	550	546	548	580	1.76	12.54	15.36	17.74	19.83	21.72	24.29	28.04	34.35
089	550	546	548	590	1.78	12.83	15.72	18.15	20.29	22.23	24.85	28.69	35.14
10	550	546	548	600	1.88	14.41	17.65	20.38	22.79	24.97	27.91	32.23	39.47
11	550	546	548	620	1.97	15.86	19.42	22.42	25.07	27.46	30.70	35.45	43.42
124	550	546	548	640	2.09	17.87	21.89	25.28	28.26	30.96	34.61	39.97	48.95
131	550	546	548	650	2.15	18.89	23.13	26.71	29.86	32.71	36.57	42.23	51.72
139	550	546	548	660	2.22	20.04	24.54	28.34	31.68	34.70	38.80	44.80	54.87
15	550	546	548	670	2.30	21.62	26.48	30.58	34.19	37.45	41.87	48.35	59.22
165	550	546	548	690	2.41	23.79	29.13	33.64	37.61	41.20	46.06	53.19	65.14
174	550	546	548	700	2.48	25.08	30.72	35.47	39.66	43.45	48.57	56.09	68.69
183	550	546	548	710	2.55	26.38	32.31	37.31	41.71	45.69	51.08	58.99	72.24
20	550	546	548	720	2.66	28.83	35.31	40.78	45.59	49.94	55.84	64.47	78.96
218	550	546	548	740	2.77	31.43	38.49	44.44	49.69	54.43	60.86	70.27	86.07
25	550	546	548	760	2.96	36.04	44.14	50.97	56.99	62.43	69.80	80.60	98.71
294	550	546	548	790	3.22	42.38	51.91	59.94	67.01	73.41	82.07	94.77	116.06
310	550	546	548	800	3.30	44.69	54.73	63.20	70.66	77.40	86.54	99.93	122.39

B = bore diameter

Connection code	Connection	p_{max} [bar]
A3. 00	BSPT	approx. 700
A3. 07	NPT	approx. 700
A3. 29	Retaining nut	approx. 300

Example for ordering: Nozzle code 550 + Flow rate code 360 + Connection code A3. 07 = Ordering no. 550. 360. A3. 07 (Solid stream; 4.52 l/min. at 100 bar; 1/8 NPT)

* Only valid for operation at constant pressure





Eductor nozzles

Series 500.262/500.428

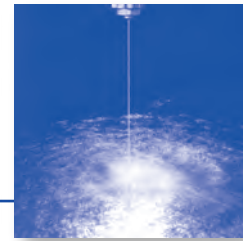

No risk of blockage thanks to the large cross sections from 2.0 to 10.0 bar.

Application:
Tank mixing, liquid circulation,
preventing sedimentation

Material:

- 1 Polypropylene
- 2 + 3 Polypropylene
Fibreglass reinforced

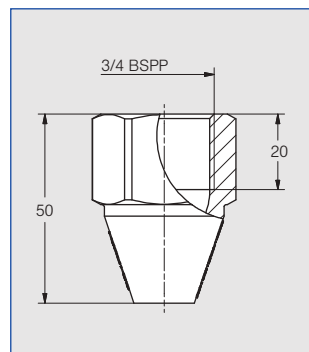
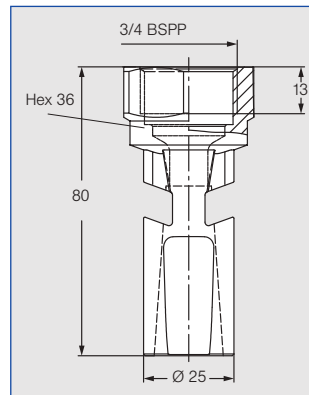
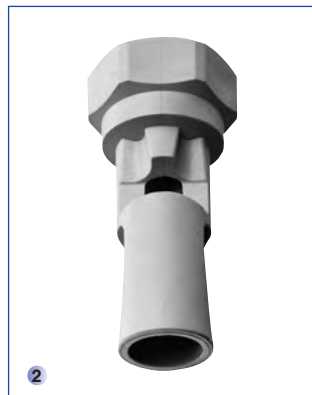
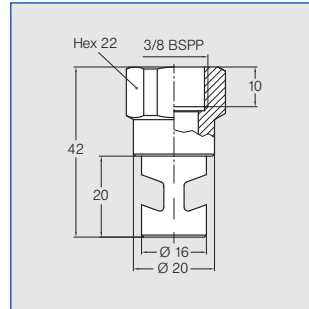

Ordering no.	B Ø [mm]	V̇ [l/min]				
		p [bar]				
		2	4	6	8	10
1 500.262.53.02	2.2	4.4	6.3	7.7	8.9	9.9
500.262.53.04	3.6	11.1	15.7	19.2	22.1	27.7
500.262.53.06	4.5	18.3	26.0	31.8	36.7	41.0
500.262.53.08	6.0	31.6	44.7	54.8	63.2	70.7
2 500.262.53.20	10.6	96.1	136.0	166.5	192.3	215.0
3 500.428.53.00	9.7	86.6	122.5	150.1	173.3	193.7

Other sizes on request.



Accessories

Eyelet clamps/Retaining nuts

Eyelet clamps with bajonett quick-release system

Eyelet clamps

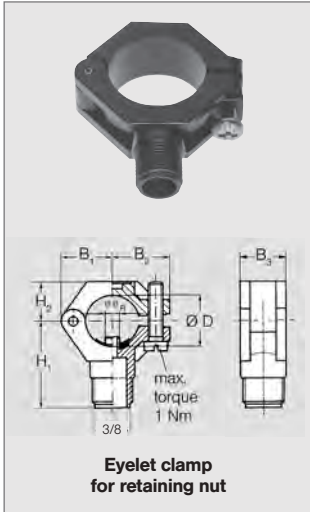

For series	Ordering no.			Screw (Material)	Dimensions [mm]										Weight (Polyamide)	
	Type	Material no.			BSPP	Pipe Ø	D Ø	B _R * Ø	B ^{**} Ø	B ₁	B ₂	B ₃	H ₁	H ₂		
		51	53													5E
302/684/652	090.053	○	○	○	304 SS	3/8	3/8"	16.5-18.0	6.0	6.2-6.4	19.0	22.0	18.5	34.5	14.5	20 g
	090.003	○	○	○		3/8	1/2"	20-22.0	6.0	6.2-6.4	21.2	23.8	18.5	36.5	16.5	20 g
	090.013	○	○	○		3/8	3/4"	25-27.5	7.6	7.8-8.0	24.5	26.5	22.0	39.5	17.5	25 g
	090.023	○	○	○		3/8	1"	32-34.5	10.6	10.8-11.0	30.0	31.0	22.0	44.0	21.0	32 g
	090.033	○	○	○		3/8	1 1/4"	40-43.0	12.6	12.8-13.0	34.0	35.5	25.0	48.0	25.0	38 g

Retaining nuts

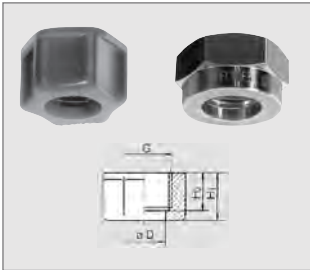

For series	Type	Ordering no.						Dimensions [mm]					Weight (Brass)
		Material no.						BSPP	H ₁	H ₂	D	Hex	
		16	17	30	56	5E	1Y						
652/660/684	065.200	○	○	○	-	-	-	3/8	13.0	10.0	12.8	22	25 g
	065.200	-	-	-	○	○	-	3/8	14.5	11.5	12.8	22	
	069.000	-	-	-	-	-	○	11/16-16 UN	14.3	11.9	13.1	21	

Eyelet clamps

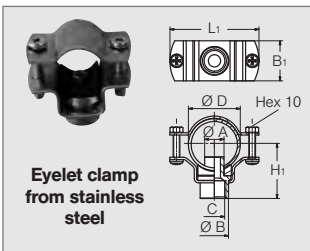

For series	Type	Ordering no.			Dimensions						
		Female thread (C)			Pipe Ø	D	L ₁	B ₁	H ₁	A Ø	B Ø
		1/8"	1/4"	3/8"							
All nozzles with 1/8", 1/4" or 3/8" male thread	090.000.16	AB	AD	-	1/2"	20-22.0	52	30	32	7	18
	090.010.16	AB	AD	-	3/4"	25-27.5	56	25	34.5	7	18
	090.020.16	AB	AD	AF	1"	32-34.5	58	30	39	7	18
	090.030.16	-	AD	AF	1 1/4"	40-43.0	70	37	46.5	17.5	25.4

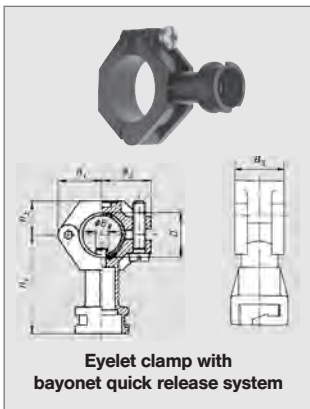

For series	Type	Ordering no.				Screw (Material)	Pipe Ø	D Ø [mm]	Dimensions [mm]						Weight		
		Material no.							Code	H ₁	H ₂	B _R * Ø	B ^{**} Ø	B ₁		B ₂	B ₃
		51	53	5E	56												
302 bayonet 422 bayonet/2TR 468/548/646 652/679/684	090.003	○	○	○	-	304 SS	1/2"	20 - 22.0	49.5	16.5	6.0	6.2 - 6.4	21.2	23.8	18.5	22g	
	090.013	○	○	○	-		3/4"	25 - 27.5	52.5	17.5	7.6	7.8 - 8.0	24.5	26.5	22.0	26g	
	090.023	○	○	○	-		1"	32 - 34.5	57.0	21.0	10.6	10.8 - 11.0	30.0	31.0	22.0	32g	



Accessories

Bayonet quick-release system

Bayonet nipple

Bayonet quick-release system

incl. gasket 065. 242. 73
(Material: rubber)

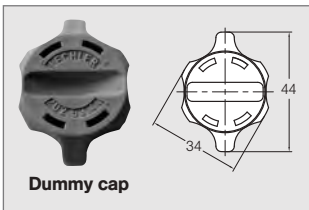
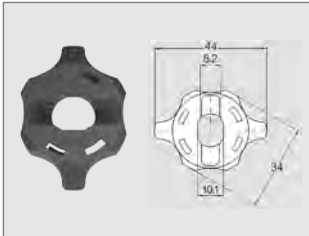

For series	Ordering no.	Material	Colour
652	065. 202. 56. 00	POM	red
	065. 202. 53. 00	Polypropylene	grey
	065. 202. 5E. 00	PVDF	blue
548/684	065. 202. 56. 11	POM	black
	065. 202. 53. 11	Polypropylene	grey

Ordering no.	Material	Colour
065. 202. 56. 40	POM	beige
065. 202. 53. 40	Polypropylene	grey

Bayonet-Nipple

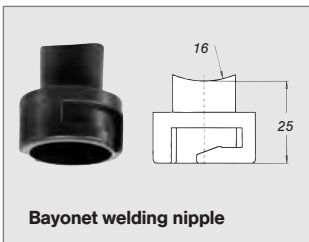

For series	Ordering no.	Material	Twist angle to the pipe axis	
			Angle	Direction
646/652/684	① 095. 016. 50. 10. 85	PVC	0°	
	② 095. 016. 53. 08. 05	PP	10°	right
	③ 095. 016. 53. 09. 29	PP	10°	left
	④ 095. 016. 53. 09. 99	PP	35°	right
	⑤ 095. 016. 53. 09. 98	PP	35°	left
	⑥ 095. 016. 53. 07. 36	PP	45°	right
	⑦ 095. 016. 53. 09. 30	PP	45°	left
	⑧ 095. 016. 53. 10. 87	PP	55°	right
	⑨ 095. 016. 53. 10. 88	PP	55°	left

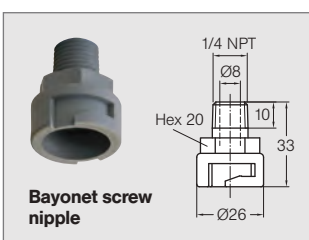

For series	Ordering no.	Material	Connection
652 684	090. 075. 53. 00	PP	1/4 NPT

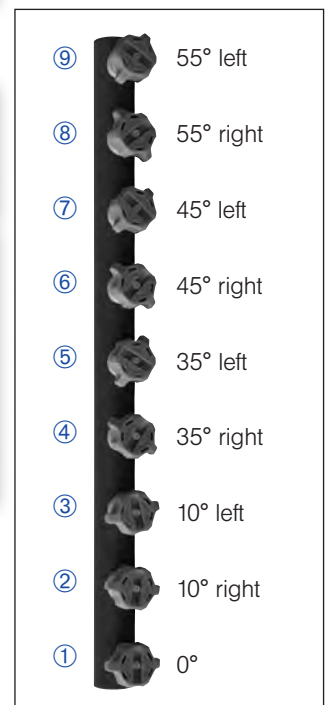

Nozzle mounting with different twist angles



Accessories

Ball joint for bayonet quick-release system

Compact ball joints for narrow installation conditions

Ball joint for bayonet quick-release system

Inexpensive ball joint system for nozzles with 1/8" and 1/4" male thread.

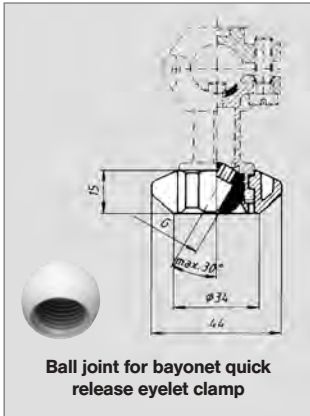

For series	Ordering no.			Colour
	Type	Mat. no.		
		5E	1/8 BSPP	
For all nozzles with 1/8" or 1/4" male thread.	092. 150	●	AB AD	blue



Pressure/Temperature

T	p _{max}
65 °C	10 bar
80 °C	8 bar
100 °C	4 bar

For series	Ordering no.	Material	Colour
For ball joint	092. 150. 5E. 00	PVDF	blue

Compact ball joints for narrow installation conditions

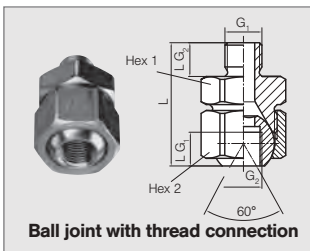

For Series	Ordering no.			Dimensions [mm]							Weight (Brass)	
	Type	Material no.		Code	G ₁ BSPP	G ₂ BSPP	L _{G1}	L _{G2}	L	Hex ₁		Hex ₂
		16	30									
For all nozzles with 1/8" male thread.	092. 010	303 SS	Brass	AA	1/8	1/8	8.0	8.0	29.3	22	24	70 g
For all nozzles with 1/4" male thread.	092. 024			AC	1/4	1/4	12.0	12.0	44	27	27	140 g
For all nozzles with 3/8" male thread.	092. 030			AE	3/8	3/8	12.0	12.0	44	27	30	160 g

Example Type + Material no. + Code = Ordering no.
for ordering: 092. 010 + 16 + AA = 092. 010. 16. AA



Accessories

Quick-release couplings

Pipe spacer



Quick-fit pipe connection (male thread)

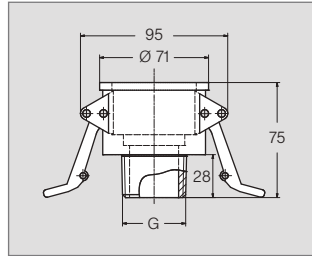

Ordering no.	Material	G	Colour
092.301.53.32.B0	PP	1 1/4 NPT	Red
092.301.53.40.B0	PP	1 1/2 NPT	Purple



Quick-fit pipe connection (female thread)

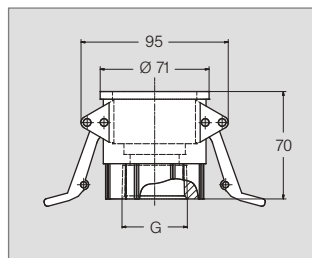

Ordering no.	Material	G	Colour
092.300.53.32.D0	PP	1 1/4 BSPT	Red
092.301.53.40.D0	PP	1 1/2 NPT	Purple

Version with thread G 1 1/4 ISO 228 made of stainless steel available on request (different dimensions).



Adapter (male thread)

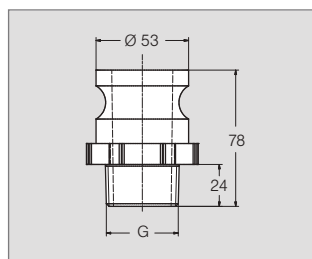

Ordering no.	Material	G	Colour
092.301.53.32.F0	PP	1 1/4 NPT	Red
092.301.53.40.F0	PP	1 1/2 NPT	Purple



Adapter (female thread)

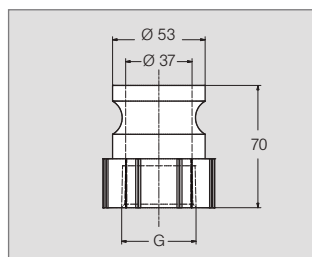

Ordering no.	Material	G	Colour
092.300.53.32.A0	PP	1 1/4 BSPT	Red
092.301.53.40.A0	PP	1 1/2 NPT	Purple

Version with thread G 1 1/4 ISO 228 made of stainless steel available on request (different dimensions).



Plug

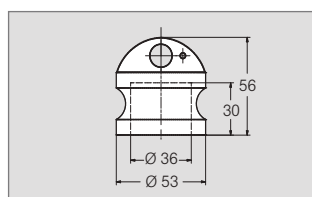

Ordering no.	Material	Colour
092.300.53.32.DP	PP	Red

Pipe spacer

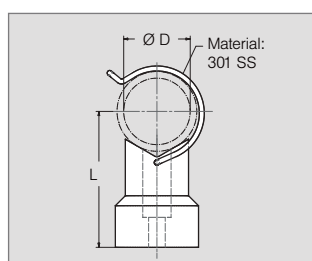

Ordering no.	Material	For pipe-Ø	Dimensions (mm)	
			L	Ø D
092.400.53.25.00	PP/301 SS	1" (32.0–34.5 mm)	75	25
092.400.53.32.00	PP/301 SS	1 1/4" (40.0–43.0 mm)	79	32
092.400.53.40.00	PP/301 SS	1 1/2" (46.0–49.0 mm)	83	40
092.400.53.50.00	PP/301 SS	2" (58.0–62.0 mm)	89	50

(incl. attachment material: screw, hexagon nut, washer, details on request)

Version with two clips available on request









YOU WILL FIND OTHER NOZZLES FOR USE IN SURFACE TECHNOLOGY IN OUR STANDARD CATALOGUE ...







Over the years, our catalogue "Precision Spray Nozzles and Accessories" has become an in-demand nozzle technology

handbook. It contains valuable tools and comprehensive technical information on Lechler products.

For a long time, many Lechler products have been used to satisfy a very wide range of surface treatment applications.

Pneumatic atomizing nozzles	Series	Spray pattern	Mode of liquid supply	Mixing of fluids		\dot{V} Water [l/h]	Application/Design	Catalogue Page
	136	Full cone or flat fan	Pressure principle or suction principle	Internal or external	20° 45° 60° 80°	0.10 – 132.90	Humidification of air, cooling.	1.3
Axial-flow hollow cone nozzles	Series		\dot{V} [l/min] at p = 2 bar	Connection	Application/Design	Catalogue page		
	220	60° 80°	0.013 – 0.390 (at p = 5 bar)	1/4 BSPP	Disinfection, humidification, cooling. Extremely fine, fog-like hollow cone spray.	2.5		
Eccentric hollow cone nozzles	Series		\dot{V} [l/min] at p = 2 bar	Connection	Application/Design	Catalogue page		
	302	60° 80° 90° 130°	0.40 – 25.00	3/8 BSPP	Humidification of air in air washers, dust control, spraying onto filters, foam control, cooling. Non-clogging nozzle design, without swirl insert.	2.8 2.9		
Full cone nozzles	Series		\dot{V} [l/min] at p = 2 bar	Connection	Application/Design	Catalogue page		
	422 423	60° 90° 120°	1.00 – 100.00	1/4 BSPT 3/8 BSPT 1/2 BSPT 3/4 BSPT 1 BSPT	Cleaning and washing process, cooling of gaseous fluids and solids, surface spraying, spraying onto mats in air washers, improving on chemical reactions, continuous casting. Without swirl inserts, non-clogging.	3.12 3.13		

Full cone nozzles	Series		\dot{V} [l/min] at $p = 2$ bar	Connection	Application/ Design	Catalogue page
	502	70°	1.25 – 60.00	1/2 BSPP 3/4 BSPP	Cooling of gaseous and solid material, desuperheating, chlorine precipitation, absorption as well as for improvement of chemical reaction by enlarging the contact area. Fine full cone atomization with the aid of several hollow cones spraying into one another.	3.15
	503	130°				
Flat fan nozzles	Series		\dot{V} [l/min] at $p = 2$ bar	Connection	Application/ Design	Catalogue page
	660		0.05 – 10.00	Assembly with 3/8" lock nut and dove-tail guide	Cleaning installations, cooling headers, spray pipes. Automatic jet alignment, due to dove-tail guide.	4.8

... AND IN DIFFERENT SPECIAL BROCHURES

We have a collection of information, included in individual subject brochures, covering special nozzles that are also of particular interest to surface technology applications.

All documents can be downloaded from our website at www.lechler.com. We would also be happy to send you the brochures.



Brochure „Precision Spray Nozzles for Tank and Equipment Cleaning“

Brochure „Air Nozzles and Accessories“

FULL INFORMATION IS JUST A CLICK AWAY: THE LECHLER WEBSITE



On the internet you can also find additional information about our entire range of services, work aids, our global presence and much more besides – we look forward to your visit.

www.lechler.com



3D DESIGN DATA FOR YOUR WORK



<http://lechler.partcommunity.com>

3D design data for Lechler nozzles and accessories is now available to you free of charge for your design work.

- Time-saving, immediate download of design drawings and technical data
- Simple, fast product selection
- Preview function with product photo and 3D graphics
- All popular 3D formats available
- Free use following one-time registration

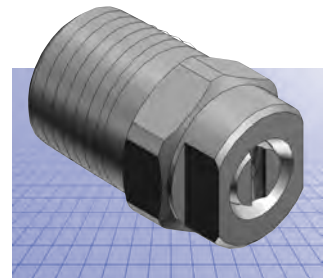

LECHLER INDUSTRY APP



Android (Google)



iOS (Apple)



All important calculation and conversion programs for nozzle technology combined in one App.

- Unit converter for pressure, volume and flow rate
- Pressure/flow rate calculator for single-fluid nozzles incl. axial-flow full cone nozzles
- Calculation of pipe diameters

FOR YOUR NOTES

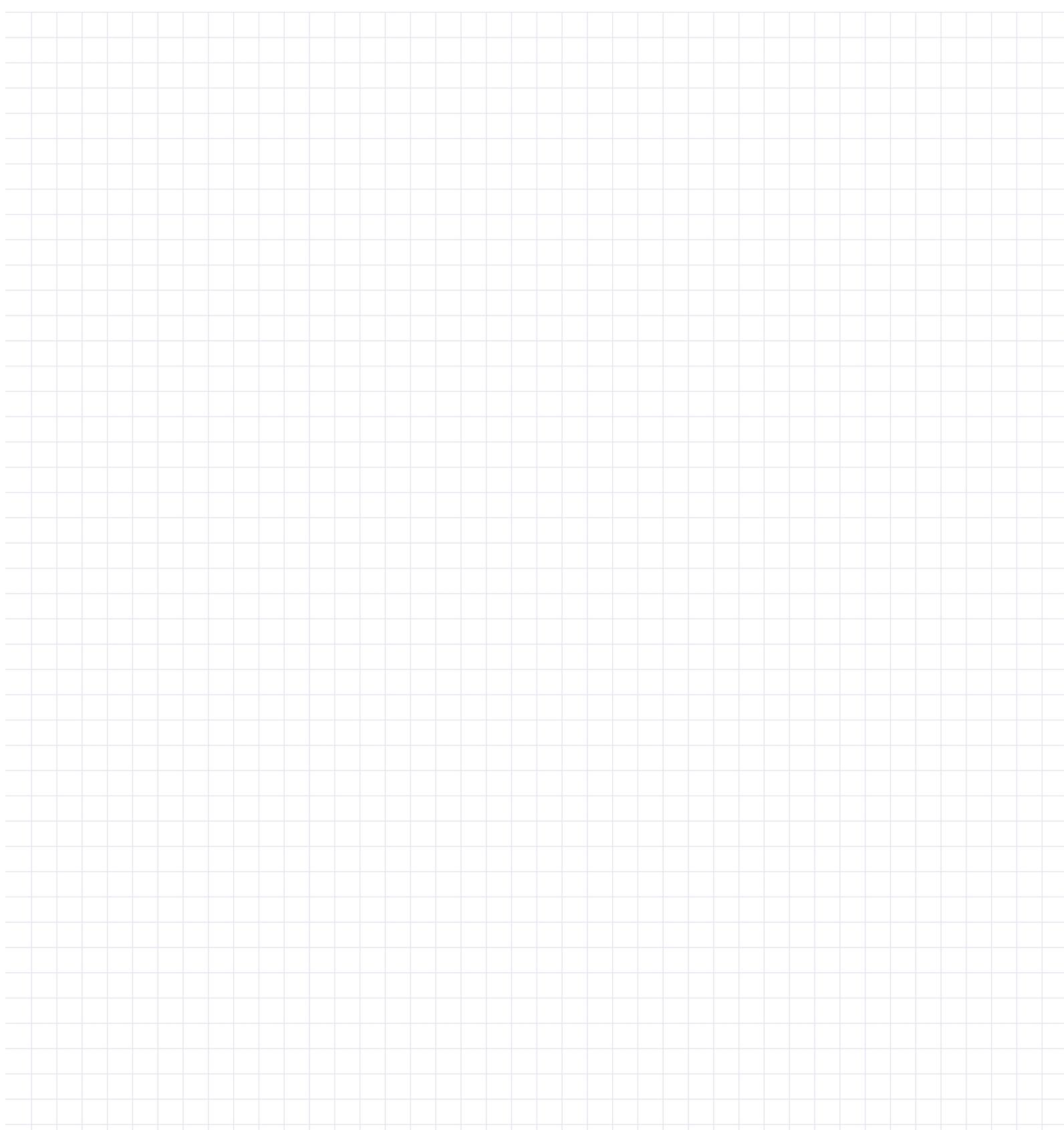

FOR YOUR NOTES

FOR YOUR NOTES



ENGINEERING
YOUR SPRAY SOLUTION



Lechler GmbH · Precision Nozzles · Nozzle Systems

Ulmer Strasse 128 · 72555 Metzingen, Germany · Phone +49 7123 962-0 · info@lechler.de · www.lechler.com

ASEAN: Lechler Spray Technology Sdn. Bhd. · 22, Jln. Astaka 4B/KU2 · Bdr. Bukit Raja · 41050 Klang · Malaysia · Phone +603 3359 1118 · info@lechler.com.my

Belgium: Lechler S.A./N.V. · Avenue Newton 4 · 1300 Wavre · Phone +32 10 225022 · info@lechler.be

China: Lechler Nozzle Systems (Changzhou) Co., Ltd. · No.99 Decheng Rd, Jintan, Changzhou, JS 213200, P.R.C · Phone +86 519-6822 8088 · info@lechler.com.cn

Finland: Lechler Oy · Ansatie 6 a C 3 krs · 01740 Vantaa · Phone +358 207 856880 · info@lechler.fi

France: Lechler France SAS · Parc de la Haute Maison · 6, Allée Képler, Bâtiment C2 · 77420 Champs-sur-Marne · Phone +33 1 49882600 · info@lechler.fr

Great Britain: Lechler Ltd. · 1 Fell Street, Newhall · Sheffield, S9 2TP · Phone +44 114 2492020 · info@lechler.com

India: Lechler (India) Pvt. Ltd. · Plot B-2 · Main Road · Wagle Industrial Estate Thane · 400604 Maharashtra · Phone +91 22 40634444 · lechler@lechlerindia.com

Italy: Lechler Spray Technology S.r.l. · Via Don Dossetti, 2 · 20080 Carpiano (Mi) · Phone +39 2 98859027 · info@lechleritalia.com

Russia: Lechler Rus · OOO, 108811, Moscow, Settlement Moskovskiy, Kiewskoe Chaussee km 22 · Object 4, Bld. 2, Block G, Floor 6, Office 601/G · info@lechler-rus.ru

Spain: Lechler, S.A. · C / Isla de Hierro, 7 – Oficina 1.3 · 28703 San Sebastián de los Reyes (Madrid) · Phone +34 91 6586346 · info@lechler.es

Sweden: Lechler AB · Hävertgatan 29 · 252 423 Helsingborg · Phone +46 18 167030 · info@lechler.se

USA: Lechler Inc. · 445 Kautz Road · St. Charles, IL 60174 · Phone +1 630 3776611 · info@lechlerusa.com