



Tongue-type nozzles

Series 688 / 689



Hard, sharp flat fan, narrowly delimited jet pattern. Non-clogging.

Applications:

Cleaning, pickling, rinsing, cross spray, requiring powerful and concentrated water jets.

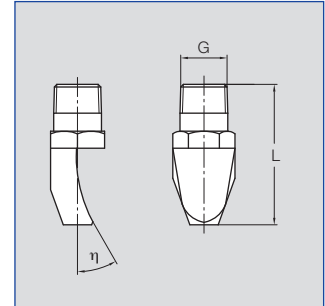

Spray angle 	η	Ordering no.							B Ø [mm]	V̇ [l/min]			Dimensions						Spray width B				
		Type	Mat. no.		Code					p [bar]			L [mm]			Hex [mm]				at p=2 bar			
			17 ¹	5E	3/8 BSPT	3/8 BSPP	1/2 BSPT	1/2 BSPP		3/4 BSPP	1.0	2.0	5.0	R 3/8	R 1/2	R 3/4	R 3/8	R 1/2			R 3/4	H = 250 mm	H = 500 mm
			AISI 316Ti/ AISI 316L	PVDF																			
15°	10°	688.921	○	-	-	-	-	CG	-	4.7	14.14	20.00	31.62	-	103	-	-	22	-	65	120		
	9°	689.001	○	-	-	-	-	AK	6	22.27	31.50	49.81	-	-	141	-	-	27	65	120			
	9°	689.121	○	-	-	-	-	AK	8.6	44.55	63.00	99.61	-	-	168	-	-	27	65	120			
30°	17°	688.922	○	-	-	-	-	CG	-	4.7	14.14	20.00	31.62	-	73	-	-	22	-	160	310		
	17°	689.002	○	-	-	-	-	AK	6	22.27	31.50	49.81	-	-	86,5	-	-	27	160	310			
	15°	689.082	○	-	-	-	-	90	AK	7.6	35.36	50.00	79.06	-	-	97,5	-	-	27	160	310		
	15°	689.122	○	-	-	-	-	AK	8.6	44.55	63.00	99.61	-	-	108,5	-	-	27	160	310			
45°	35°	688.763	○	○	CE	-	-	-	-	3	5.66	8.00	12.65	42	-	-	19	-	-	220	440		
	30°	688.843	○	○	CE	-	-	-	-	3.8	8.84	12.50	19.76	49,5	-	-	19	-	-	220	440		
	29°	688.923	○	-	CE	-	-	-	-	4.8	14.14	20.00	31.62	58,5	-	-	22	-	-	220	440		
	29°	688.923	-	○	-	AE	-	-	-	4.8	14.14	20.00	31.62	54	-	-	22	-	-	220	440		
	35°	689.003	○	-	CE	-	90	AK	6	22.27	31.50	49.81	65	-	73,5	24	-	27	250	490			
	21°	689.043	○	-	CE	-	-	-	-	6.9	28.28	40.00	63.25	66,5	-	-	24	-	-	250	490		
	18°	689.083	○	-	-	-	-	AK	7.6	35.36	50.00	79.06	-	-	73,5	-	-	27	250	490			
	18°	689.123	○	-	CE	-	-	-	-	8.6	44.55	63.00	99.61	78,5	-	-	24	-	-	250	490		

¹We reserve the right to deliver AISI 316Ti or AISI 316L under the material no. 17.

B = bore diameter

Other types on request.

Example of ordering: Type + Material no. + Code = Ordering no.
688.921 + 17 + CG = 688.921.17.CG



Conversion formula for the above series: $\dot{V}_2 = \dot{V}_1 \cdot \sqrt{\frac{p_2}{p_1}}$